



SAN FRANCISCO PLANNING DEPARTMENT

MEMO

Memo to the Planning Commission

HEARING DATE: JANUARY 30, 2020
CONTINUED FROM DECEMBER 12, 2019

DATE: January 23, 2020
TO: Planning Commission
FROM: Linda Ajello Hoagland, Planner 2018-011904CUA
RE: 1420 Taraval Street Update (Case No. 2018-011904CUA)

1650 Mission St.
Suite 400
San Francisco,
CA 94103-2479

Reception:
415.558.6378

Fax:
415.558.6409

Planning
Information:
415.558.6377

BACKGROUND

On December 12, 2019, the Planning Commission continued the Conditional Use Authorization for 1420 Taraval Street to the public hearing on January 30, 2020, with the direction to provide more information and updated plans to better substantiate the Project. The Project Sponsor has since submitted revised plans providing additional information, as follows:

- Printing errors have been resolved and proposed elevations are now visible;
- The location of the master bedroom and living room have been reversed so the living room now faces the street;
- The rear yard roof deck has been setback 5-feet from the eastern property line and planters have been added along the north and east sides;
- Planters have been added on the north and south sides of the roof deck;
- The location of elevator has been shifted further toward the rear of the building;
- The width of the storefront display area has been increased;
- A 6-foot high opaque screen has been added at the north and east sides of the roof deck to address privacy concerns; and
- The 30-inch high roof parapet has been eliminated.

No changes were made to the total building area, residential gross square footage, or number of residential units.

Attachments:

- Draft Motion
- Updated Plans



SAN FRANCISCO PLANNING DEPARTMENT

Planning Commission Draft Motion

HEARING DATE: JANUARY 30, 2020

1650 Mission St.
Suite 400
San Francisco,
CA 94103-2479

Reception:
415.558.6378

Fax:
415.558.6409

Planning
Information:
415.558.6377

Record No.: 2018-011904CUA
Project Address: 1420 TARAVAL STREET
Zoning: Taraval Street Neighborhood Commercial District (NCD) Zoning District
65-A Height and Bulk District
Taraval Street Restaurant Subdistrict
Block/Lot: 2353/010
Project Sponsor: William Pashelinsky
1937 Hayes Street
San Francisco, CA 94117
Property Owner: Peter Mandel
San Francisco, CA 94127
Staff Contact: Linda Ajello Hoagland, AICP – (415) 575-6823
linda.ajellohoagland@sfgov.org

ADOPTING FINDINGS RELATING TO THE APPROVAL OF A CONDITIONAL USE AUTHORIZATION PURSUANT TO PLANNING CODE SECTIONS 303 AND 317, TO DEMOLISH A 2,176 SQUARE FOOT, THREE-STORY SINGLE-FAMILY RESIDENCE, AND CONSTRUCT A NEW, APPROXIMATELY 6,219 SQUARE FOOT, FOUR-STORY, 45-FOOT TALL, MIXED-USE BUILDING WITH THREE DWELLING UNITS AND APPROXIMATELY 1,731 SQUARE FEET OF GROUND FLOOR COMMERCIAL WITHIN THE TARAVAL STREET NEIGHBORHOOD COMMERCIAL (NCD) ZONING DISTRICT AND A 65-A HEIGHT AND BULK DISTRICT, AND ADOPTING FINDINGS UNDER THE CALIFORNIA ENVIRONMENTAL QUALITY ACT.

PREAMBLE

On August 30, 2018, William Pashelinsky (hereinafter "Project Sponsor") filed Application No. 2018-011904CUA (hereinafter "Application") with the Planning Department (hereinafter "Department") for a Conditional Use Authorization to demolish an existing 3-story single family dwelling and construct a new four-story, 45-ft tall, mixed-use building with 3 dwelling units and 1,731 square feet of ground floor commercial use (hereinafter "Project") at 1420 Taraval Street, Block 2353 Lot 010 (hereinafter "Project Site").

The Project is exempt from the California Environmental Quality Act ("CEQA") as a Class 1 and Class 3 categorical exemption.

On December 12, 2019, the San Francisco Planning Commission (hereinafter "Commission") conducted a duly noticed public hearing at a regularly scheduled meeting on Conditional Use Authorization Application No. 2018-011904CUA. At the public hearing, the Planning Commission continued the Project to the public hearing on January 30, 2020.

The Planning Department Commission Secretary is the custodian of records; the File for Record No. 2018-011904CUA is located at 1650 Mission Street, Suite 400, San Francisco, California.

The Commission has heard and considered the testimony presented to it at the public hearing and has further considered written materials and oral testimony presented on behalf of the applicant, Department staff, and other interested parties.

MOVED, that the Commission hereby authorizes the Conditional Use Authorization as requested in Application No. 2018-011904CUA, subject to the conditions contained in "EXHIBIT A" of this motion, based on the following findings:

FINDINGS

Having reviewed the materials identified in the preamble above, and having heard all testimony and arguments, this Commission finds, concludes, and determines as follows:

1. The above recitals are accurate and constitute findings of this Commission.
2. **Project Description.** The Project includes the demolition of an existing 2,176 square foot, three-story, single-family home and construction of a new four-story, 45-ft tall, mixed use building (approximately 6,219 square feet) with 3 dwelling units, approximately 1,731 square feet of ground floor commercial use, 1,392 square feet of open space through a combination of private and common opens space, including a roof deck, and 3 Class 1 bicycle parking spaces. No off-street parking is proposed. The Project includes a dwelling-unit mix consisting of 3 (approximately 1,600 square foot each), three-bedroom and 2 bath units.
3. **Site Description and Present Use.** The Project is located on the north side of Taraval Street, between 24th and 25th Avenues; Lot 010 in Assessor's Block 2353 within the Taraval Street Neighborhood Commercial District (NCD) Zoning District with a 65-A Height and Bulk District. The site is an approximately 2,500 square foot uphill sloping lot with 25 feet of frontage and a depth of 100 feet. The project site has an existing approximately 2,176 square foot, three-story, single-family home constructed circa 1900. The structure is currently used as a rental property with the current lease expiring prior to the start of construction. There is no off-street parking for the property.
4. **Surrounding Properties and Neighborhood.** The subject property is located in the Parkside neighborhood. Parcels within the immediate vicinity consist of two- to three-story single- and multi-family dwellings, single- and two-story commercial buildings and two- to four-story mixed-use buildings of varied design and construction dates. The block-face is characterized by two- to three-story buildings of mixed architectural style. The adjacent properties to the east and west are improved with a two-story commercial building and a three-story multi-family dwelling constructed in 1968 and 1936, respectively, and a three-story multi-family dwelling to the north, constructed in 1927. The surrounding properties are located in the Taraval Street NCD, RH-1

(Residential-House, One-Family), and RM-1 (Residential-Mixed, Low Density) Zoning Districts. The subject property is also within .25-miles of stops for the L and L-OWL MUNI transit lines.

5. **Public Outreach and Comments.** To date, the Department has received three comments expressing opposition to the demolition of the existing 1907 building due to its historical value in the neighborhood.
6. **Planning Code Compliance.** The Commission finds that the Project is consistent with the relevant provisions of the Planning Code in the following manner:

- A. **Permitted Uses in Taraval Street NCD Zoning District.** Planning Code Section 733 states that residential and commercial uses are permitted within the Taraval Street NCD Zoning District.

The Project would construct a four-story, mixed-use building with three dwelling units with ground floor commercial and, therefore complies with Planning Code Section 733.

- B. **Residential Demolition – Section 317.** Pursuant to Planning Code Section 317, Conditional Use Authorization is required for applications proposing to demolish a residential unit in any Zoning District. The Code establishes criteria that the Planning Commission shall consider in the review of applications for residential demolition.

As the Project requires Conditional Use Authorization per the requirements of Section 317, the additional criteria specified under Section 317 have been incorporated as findings as part of this Motion (See Below).

- C. **Rear Yard.** Planning Code Section 134 requires a minimum rear yard equal to 25 percent of the total lot depth of the lot to be provided at the second story and at each succeeding level or story of the building, and at the first story if it contains a dwelling unit.

The Project site is 100 feet deep and provides a 25-foot rear yard at the second level (first residential level) and would comply with Planning Code Section 134.

- D. **Usable Open Space.** Planning Code Sections 135 and 733 require 100 square feet of usable open space per unit if private, or 133 square feet if common.

The Project provides approximately 558 square feet of private open space for unit one within the rear yard area and two, approximately 380 square foot, private roof decks for units two and three. The private open space areas for all units exceeds the 100 square feet required; therefore, the Project provides code-complying open space for all dwelling units.

- E. **Bird Safety.** Planning Code Section 139 outlines the standards for bird-safe buildings, including the requirements for location-related and feature-related hazards.

The subject lot is located within 300 feet of a possible Urban Bird Refuge as defined in Section 139, and the Project meets the requirements for feature-related hazards.

- F. **Dwelling Unit Exposure.** Planning Code Section 140 requires that at least one room of all dwelling units face onto a public street, rear yard or other open area that meets minimum requirements for area and horizontal dimensions. To meet exposure requirements, a public street, public alley, side yard or rear yard must be at least 25 feet in width.

The Project organizes the dwelling units to have exposure on Taraval Street or the code-complying rear yard; therefore, the Project complies with Planning Code Section 140.

- G. **Shadow.** Planning Code Sections 147 and 295 restricts net new shadow, cast by structures exceeding a height of 40 feet, upon property under the jurisdiction of the Recreation and Park Commission. Any project in excess of 40 feet in height and found to cast net new shadow must be found by the Planning Commission, with comment from the General Manager of the Recreation and Parks Department, in consultation with the Recreation and Park Commission, to have no adverse impact upon the property under the jurisdiction of the Recreation and Park Commission.

A shadow analysis was prepared for the project determined that the proposed project would not cast shadows on any parks or open spaces at any time during the year.

- H. **Off-Street Parking.** Planning Code Section 151.1 does not require off-street parking for residential and non-residential uses and allows for a maximum of 1.5 parking spaces for each dwelling unit and a maximum of 1.5 per 500 square feet of occupied floor area, up to 20,000 where the occupied floor area exceeds 5,000 square feet for retail sales and service uses.

The Project does not provide any off-street parking space and, therefore complies with Planning Code Section 151.1.

- I. **Bicycle Parking.** Planning Code Section 155.2 requires at least one Class 1 bicycle parking space for each dwelling unit and one Class 2 space for every 20 dwelling units. Additional bicycle parking requirements apply based on classification of non-residential uses, at least two Class 2 spaces are required for retail sales and service uses.

The Project includes three dwelling units; therefore, the Project is required to provide three Class 1 bicycle parking spaces for residential uses and two Class 2 bicycle parking spaces for the non-residential uses. The Project will provide three Class 1 bicycle parking spaces and two Class 2 bicycle parking spaces. Therefore, the Project complies with Planning Code Section 155.2

- J. **Height and Bulk.** Planning Code Sections 260 and 270 outlines the height and bulk districts within the City and County of San Francisco. Planning Code Section 270 defines the base of the building as the lowest portion of the building extending vertically to a streetwall height up to 1.25 times the width of the widest abutting street or 50 feet, whichever is more. There are no length or diagonal dimension limitations applicable to the base. The Project is located in a 65-A Height and Bulk District. Therefore, the proposed development is permitted up to a height of 65 feet and a 110-foot maximum length and 125-foot maximum diagonal for a height above 40 feet.

The Project proposes a building that will be approximately 45 feet tall, which is below the 65-foot height limit. Taraval Street is 80 feet in width, so the Project base would be considered 100 feet (80x1.25). Planning Code Section 270 states that there are no length or diagonal dimension limits applicable to the base and, therefore complies with the Planning Code and the Height and Bulk District.

- K. **Rear Yard Requirement.** Planning Code Section 134 requires a minimum rear yard depth shall be equal to 45 percent of the total depth of the lot on which the building is situated, except to the extent that a reduction in this requirement is permitted by averaging of the adjacent rear building walls. When averaging, the minimum rear yard allowed is 25%, but in no case less than 15 feet, and shall be provided at the ground level. Permitted projections into the rear yard are also permitted per Planning Code Section 136, such as a two-story addition projecting up to 12 feet into the rear yard with 5-foot side setbacks on each side for the length of the projection.

The subject property is 100 feet deep; and the average rear yard depth of the adjacent neighbors is 37 feet, 3 inches; therefore, the rear yard requirement is 37 feet, 3 inches. The Project, which includes a permitted single-story, 9-foot, 1-inch projection, complies with the rear yard requirements

- L. **Child Care Requirements for Residential Projects.** Planning Code Section 414A requires that any residential development project that results in additional space in an existing residential unit of more than 800 gross square feet shall comply with the imposition of the Residential Child Care Impact Fee requirement.

The Project proposes new construction of a building that results in two net new dwelling units. Therefore, the Project is subject to the Residential Child Care Impact Fee and must comply with the requirements outlined in Planning Code Section 414A

7. **Conditional Use Findings.** Planning Code Section 303 establishes criteria for the Planning Commission to consider when reviewing applications for Conditional Use authorization. On balance, the project complies with said criteria in that:

- A. The proposed new uses and building, at the size and intensity contemplated and at the proposed location, will provide a development that is necessary or desirable, and compatible with, the neighborhood or the community.

The use and size of the proposed project is compatible with the surrounding neighborhood. The proposal would demolish an existing, 2,176 square foot, single-family dwelling. The new building will contain approximately 1,731 square feet of ground floor commercial and three 3-bedroom dwelling units ranging in size from approximately 1,578 square feet to 1,672 square feet. The siting of the new building will be in conformity with the requirements of the Planning Code and consistent with the objectives of the Residential Design Guidelines. Overall, the construction of three new dwelling units is necessary and compatible with the surrounding neighborhood and the larger City.

- B. The proposed project will not be detrimental to the health, safety, convenience or general welfare of persons residing or working in the vicinity. There are no features of the project that could be detrimental to the health, safety or convenience of those residing or working the area, in that:

- (1) Nature of proposed site, including its size and shape, and the proposed size, shape and arrangement of structures;

The Project includes a four-story massing along the street, which is appropriate given the context of the surrounding neighborhood. The proposed building provides rear setbacks, all which help to sculpt the building to minimize impacts and remain compatible with the neighborhood's two- to-four-story buildings.

- (2) The accessibility and traffic patterns for persons and vehicles, the type and volume of such traffic, and the adequacy of proposed off-street parking and loading;

The Project would not adversely affect public transit in the neighborhood. The Project site is located close to several MUNI bus lines, including the L and L-OWL MUNI transit lines. The Project provides no off-street parking, which supports the City's transit first policies. Provision of bicycle storage areas along with the close proximity to mass transit is anticipated to encourage residents, employees and visitors to use alternate modes of transportation.

- (3) The safeguards afforded to prevent noxious or offensive emissions such as noise, glare, dust and odor;

The Project will comply with Title 24 standards for noise insulation. The Project will also be subject to the standard conditions of approval for lighting and construction noise. Construction noise impacts would be less than significant because all construction activities would be conducted in compliance with the San Francisco Noise Ordinance (Article 29 of the San Francisco Police Code, as amended May 2014). The SF Board of Supervisors approved the Construction Dust Control Ordinance (Ordinance 176-08, effective July 30, 2008) with the intent of reducing the quantity of dust generated during site preparation,

demolition and construction work in order to protect the health of the general public and of on-site workers, minimize public nuisance complaints, and to avoid orders to stop work by the Department of Building Inspection. Therefore, the Project would be required to follow specified practices to control construction dust and to comply with this ordinance. Overall, the Project is not expected to generate dust or odor impacts.

- (4) Treatment given, as appropriate, to such aspects as landscaping, screening, open spaces, parking and loading areas, service areas, lighting and signs;

The Project will provide the required number of street trees and bicycle parking along the public-rights-of-way.

- C. That the use as proposed will comply with the applicable provisions of the Planning Code and will not adversely affect the General Plan.

The Project complies with all relevant requirements and standards of the Planning Code and is consistent with objectives and policies of the General Plan as detailed below.

- D. That the use as proposed would provide development that is in conformity with the purpose of the applicable Neighborhood Commercial District.

The proposed Project is consistent with the stated purposes of the Taraval Street Neighborhood Commercial District (NCD) in that the commercial use is located at the ground floor, protects the rear yard at residential levels and is consistent with the Planning Code for mixed-use buildings in the Taraval Street NCD.

8. **Additional Findings pursuant to Section 317** establishes criteria for the Planning Commission to consider when reviewing applications for Residential Demolition. On balance, the Project does comply with said criteria in that:

- i. Whether the property is free of a history of serious, continuing Code violations;

A review of the Department of Building Inspection and the Planning Department databases showed no open enforcement cases or notices of violation for the subject property.

- ii. Whether the housing has been maintained in a decent, safe, and sanitary condition;

The existing dwelling is currently used as a rental and does not have any past code-violations.

- iii. Whether the property is an "historical resource" under CEQA;

Although the existing structure is more than 50 years old, a review of the supplemental information resulted in a determination that the structure is not a historical resource.

- iv. Whether the removal of the resource will have a substantial adverse impact under CEQA;

Not Applicable. The existing structure is not a historic resource.

- v. Whether the project converts rental housing to other forms of tenure or occupancy;

The Project does not convert rental housing to other forms of tenure or occupancy, as the existing building is a single-family residence and is used as such.

- vi. Whether the project removes rental units subject to the Residential Rent Stabilization and Arbitration Ordinance or affordable housing;

The existing single-family dwelling is used as a rental property. Although the single-family dwelling is technically subject to the Rent Stabilization and Arbitration Ordinance because it is a residential building constructed before 1979, the Planning Department cannot definitively determine which aspects of the Ordinance are applicable. The Rent Stabilization and Arbitration Ordinance includes provisions for eviction controls, price controls, and other controls, and it is the purview of the Rent Board to determine which specific controls apply to a building or property. The Rent Board has confirmed that there are no database records, or any documentation indicating an eviction neither history nor eviction notices filed at the Rent Board for 1420 Taraval Street.

- vii. Whether the project conserves existing housing to preserve cultural and economic neighborhood diversity;

Although the Project proposes the demolition of an existing dwelling, the new construction will result in two additional dwelling units.

- viii. Whether the project conserves neighborhood character to preserve neighborhood cultural and economic diversity;

The Project conserves neighborhood character with appropriate scale, design, and materials, and improves cultural and economic diversity by constructing a mixed-use building with ground floor commercial and three dwelling units that are consistent with the Taraval Street NCD Zoning District. The proposed mixed-use development is characteristic of other existing residential buildings located along Taraval Street; two net new dwelling units would be added to the City's Housing Stock.

- ix. Whether the project protects the relative affordability of existing housing;

The Project removes an older dwelling unit, which is generally considered more affordable than a more recently constructed unit; however, the project will add two family-sized dwelling units to the City's Housing Stock.

- x. Whether the project increases the number of permanently affordable units as governed by Section 415;

The Project is not subject to the provisions of Planning Code Section 415, as the Project proposes less than ten units.

- xi. Whether the project locates in-fill housing on appropriate sites in established neighborhoods;

The Project proposes in-fill housing with a total of three dwelling units which is consistent with the varying neighborhood density. The proposed mixed-use development is characteristic of other existing residential buildings located along Taraval Street and in the surrounding neighborhood.

- xii. Whether the project increases the number of family-sized units on-site;

The Project proposes an opportunity for family-sized housing. Three 3-bedroom units are proposed within the new building. Currently, the property only contains one dwelling with two bedrooms.

- xiii. Whether the project creates new supportive housing;

The Project does not create new supportive housing.

- xiv. Whether the project is of superb architectural and urban design, meeting all relevant design guidelines, to enhance existing neighborhood character;

The overall scale, design, and materials of the proposed buildings are consistent with the block-face and compliment the neighborhood character with a contemporary design. The proposed residential development is characteristic of other existing residential uses along Taraval Street and in the surrounding neighborhood.

- xv. Whether the project increases the number of on-site Dwelling Units;

The Project will increase the number of on-site units from one dwelling unit to three dwelling units.

- xvi. Whether the project increases the number of on-site bedrooms.

The existing dwelling contains two bedrooms. The Project proposes a total of nine bedrooms between the three dwelling units.

- xvii. Whether or not the replacement project would maximize density on the subject lot; and

The maximum density for the subject property is three units (one dwelling unit per 800 square feet of lot area). The Project proposes the new construction of a mixed-use, three-unit building with ground floor commercial, maximizing the density permitted in the Taraval Street NCD Zoning District.

- xviii. If replacing a building not subject to the Residential Rent Stabilization and Arbitration Ordinance, whether the new project replaces all of the existing units with new Dwelling Units of a similar size and with the same number of bedrooms.

The existing single-family dwelling is currently used as a rental property. Although the single-family dwelling is technically subject to the Rent Stabilization and Arbitration Ordinance because it is a residential building constructed before 1979, the Planning Department cannot definitively determine which aspects of the Ordinance are applicable. The Rent Stabilization and Arbitration Ordinance includes provisions for eviction controls, price controls, and other controls, and it is the purview of the Rent Board to determine which specific controls apply to a building or property. The Rent Board has confirmed that there are no database records, nor any documentation indicating an eviction history nor eviction notices filed at the Rent Board for 1420 Taraval Street.

Regarding unit size and count, the existing dwelling unit has approximately 2,176 square feet of habitable area and two bedrooms. The proposed building contains three, 3-bedroom units. The new units provide more than the existing square footage and bedroom count.

9. **General Plan Compliance.** The Project is, on balance, consistent with the following Objectives and Policies of the General Plan:

HOUSING ELEMENT

Objectives and Policies

OBJECTIVE 2:

RETAIN EXISTING HOUSING UNITS, AND PROMOTE SAFETY AND MAINTENANCE STANDARDS, WITHOUT JEOPARDIZING AFFORDABILITY.

Policy 2.1:

Discourage the demolition of a sound existing housing unless the demolition results in a net increase in affordable housing.

The Project proposes to demolish an existing structure containing one bedroom and one bathroom to construct three new dwelling units each with two-bedrooms and thereby contributes to the general housing stock of the city.

**OBJECTIVE 3:
PROTECT THE AFFORDABILITY OF THE EXISTING HOUSING STOCK, ESPECIALLY
RENTAL UNITS.**

Policy 3.1:

Preserve rental units, especially rent controlled units, to meet the City's affordable housing needs.

Policy 3.3:

Maintain balance in affordability of existing housing stock by supporting affordable moderate ownership opportunities.

Policy 3.4:

Preserve "naturally affordable" housing types, such as smaller and older ownership units.

While the Project will demolish an existing single-family dwelling, the new construction will result in an increase in the density of the property and contributes two net new dwelling units, a net addition of five bedrooms, to the existing housing stock.

**OBJECTIVE 4:
FOSTER A HOUSING STOCK THAT MEETS THE NEEDS OF ALL RESIDENTS ACROSS
LIFECYCLES.**

Policy 4.1:

Develop new housing, and encourage the remodeling of existing housing, for families with children.

The Project proposes to demolish a single-family residence with one bedroom to construct three dwelling units, each with 3-bedrooms which could accommodate families with children.

**OBJECTIVE 11:
SUPPORT AND RESPECT THE DIVERSE AND DISTINCT CHARACTER OF SAN
FRANCISCO'S NEIGHBORHOODS.**

Policy 11.1:

Promote the construction and rehabilitation of well-designed housing that emphasizes beauty, flexibility, and innovative design, and respect existing neighborhood character.

Policy 11.2:

Ensure implementation of accepted design standards in project approvals.

Policy 11.3

Ensure growth is accommodated without substantially and adversely impacting existing residential neighborhood character.

Policy 11.4

Continue to utilize zoning districts which conform to a generalized residential land use and density plan and the General Plan.

Policy 11.5

Ensure densities in established residential areas promote compatibility with prevailing neighborhood character.

The subject property is within the Taraval Street Neighborhood Commercial Zoning District which allows for higher residential density than the existing single-family dwelling. The Project proposes a total of three dwelling units on a property located in a neighborhood consisting of two- to three-story single- and multi-family dwellings, single- and two-story commercial buildings and two- to four-story mixed-use buildings. Furthermore, the proposed new construction conforms to the Residential Design Guidelines and is appropriate in terms of material, scale, proportions and massing for the surrounding neighborhood.

RECREATION AND OPEN SPACE ELEMENT

Objectives and Policies

OBJECTIVE 2:

INCREASE RECREATION AND OPEN SPACE TO MEET THE LONG-TERM NEEDS OF THE CITY AND BY REGION

Policy 2.11:

Assure that privately developed residential open spaces are usable, beautiful, and environmentally sustainable.

The Project proposes two roof decks that have potential for planters and additional landscaping.

OBJECTIVE 3:

IMPROVE ACCESS AND CONNECTIVITY TO OPEN SPACE

Policy 3.6:

Maintain, restore, expand and fund the urban forest.

The Project will add to the urban forest with the addition of a new street tree.

TRANSPORTATION ELEMENT

Objectives and Policies

OBJECTIVE 24:

IMPROVE THE AMBIENCE OF THE PEDESTRIAN ENVIRONMENT.

Policy 24.2:

Maintain and expand the planting of street trees and the infrastructure to support them.

Policy 24.4:

Preserve pedestrian-oriented building frontages.

The Project will install a new street tree along Taraval Street. Frontages are designed with transparent glass and intended for active spaces oriented at the pedestrian level.

OBJECTIVE 28:

PROVIDE SECURE AND CONVENIENT PARKING FACILITIES FOR BICYCLES.

Policy 28.1:

Provide secure bicycle parking in new governmental, commercial, and residential developments.

Policy 28.3:

Provide parking facilities which are safe, secure, and convenient.

The Project includes 3 Class 1 and 2 Class 2 bicycle parking spaces in secure, convenient locations.

OBJECTIVE 34:

RELATE THE AMOUNT OF PARKING IN RESIDENTIAL AREAS AND NEIGHBORHOOD COMMERCIAL DISTRICTS TO THE CAPACITY OF THE CITY'S STREET SYSTEM AND LAND USE PATTERNS.

Policy 34.3:

Permit minimal or reduced off-street parking supply for new buildings in residential and commercial areas adjacent to transit centers and along transit preferential streets.

Policy 34.5:

Minimize the construction of new curb cuts in areas where on-street parking is in short supply and locate them in a manner such that they retain or minimally diminish the number of existing on-street parking spaces.

The Project does not provide any off-street vehicular parking, which complies with Planning Code Section 151.1.

URBAN DESIGN

OBJECTIVE 1:

EMPHASIS OF THE CHARACTERISTIC PATTERN WHICH GIVES TO THE CITY AND ITS NEIGHBORHOODS AN IMAGE, A SENSE OF PURPOSE, AND A MEANS OF ORIENTATION.

Policy 1.2:

Recognize, protect and reinforce the existing street pattern, especially as it is related to topography.

The Project proposes demolition of an existing single-family building to construct a mixed-use, three-family building with ground floor commercial use. Similar to other existing structures on the block-face, the new building proposes a ground floor commercial storefront with residential above.

Policy 1.3:

Recognize that buildings, when seen together, produce a total effect that characterizes the city and its districts.

The proposed façade and massing are compatible with the existing neighborhood character and development pattern, particularly because the proposed building is of a similar massing, width and height to the existing structures in the neighborhood. The ground floor commercial use continues the pattern of existing mixed-use buildings in the immediate area. The proposed façade and massing of the new building reflects the existing mixed architectural character, varying heights along the block face and will be in keeping with the neighborhood development pattern.

OBJECTIVE 2:

CONSERVATION OF RESOURCES WHICH PROVIDE A SENSE OF NATURE, CONTINUITY WITH THE PAST, AND FREEDOM FROM OVERCROWDING.

Policy 2.6:

Respect the character of older development nearby in the design of new buildings.

The massing of the replacement buildings' main front façades has been designed to be compatible with the prevailing street wall heights. Although interpreted in a contemporary architectural style, the proposed building proportions and exterior materials have been selected to be compatible with the adjacent buildings and the immediate neighborhood character.

10. **Planning Code Section 101.1(b)** establishes eight priority-planning policies and requires review of permits for consistency with said policies. On balance, the project does comply with said policies in that:

- A. That existing neighborhood-serving retail uses be preserved and enhanced and future opportunities for resident employment in and ownership of such businesses be enhanced.

Existing neighborhood-serving retail uses would not be displaced or otherwise adversely affected by the proposal, as the existing building does not contain commercial uses.

- B. That existing housing and neighborhood character be conserved and protected in order to preserve the cultural and economic diversity of our neighborhoods.

While the existing housing is proposed to be demolished, the replacement building would provide three dwelling units in a neighborhood made up of single-family residences to small multi-unit buildings of mixed architectural character, as well as commercial uses.

- C. That the City's supply of affordable housing be preserved and enhanced,

The existing single-family dwelling is not designated as affordable housing. The three proposed dwelling units will also not be designated as affordable housing.

- D. That commuter traffic not impede MUNI transit service or overburden our streets or neighborhood parking.

The Project Site is served by nearby public transportation options. The subject property is within .25-miles of stops for the L and L-OWL MUNI transit lines. Future residents would be afforded proximity to a bus line. The Project also provides bicycle parking for residents and their guests.

- E. That a diverse economic base be maintained by protecting our industrial and service sectors from displacement due to commercial office development, and that future opportunities for resident employment and ownership in these sectors be enhanced.

The Project does not involve the creation of commercial office development. The Project would enhance opportunities for resident employment and ownership in retail sales and service sectors by providing for new housing and commercial space, which will increase the diversity of the City's housing supply (a top priority in the City) and provide new potential neighborhood-serving uses and employment opportunities.

- F. That the City achieve the greatest possible preparedness to protect against injury and loss of life in an earthquake.

The replacement structure would be constructed in compliance with San Francisco's current Building Code Standards and would meet all earthquake safety requirements.

- G. That landmarks and historic buildings be preserved.

A City Landmark or historic building does not occupy the Project site.

- H. That our parks and open space and their access to sunlight and vistas be protected from development.

The Project will have no negative impact on existing parks and open spaces. The shadow analysis conducted for the Project concluded that no new shadows would be cast on Mc Coppin Park. The height of the proposed structure is compatible with the established neighborhood development.

11. The Project is consistent with and would promote the general and specific purposes of the Code provided under Section 101.1(b) in that, as designed, the Project would contribute to the character and stability of the neighborhood and would constitute a beneficial development.
12. The Commission hereby finds that approval of the Conditional Use Authorization would promote the health, safety and welfare of the City.

DECISION

That based upon the Record, the submissions by the Applicant, the staff of the Department and other interested parties, the oral testimony presented to this Commission at the public hearings, and all other written materials submitted by all parties, the Commission hereby **APPROVES Conditional Use Authorization Application No. 2018-011904CUA** subject to the following conditions attached hereto as "EXHIBIT A" in general conformance with plans on file, dated January 3, 2020, and stamped "EXHIBIT B", which is incorporated herein by reference as though fully set forth.

APPEAL AND EFFECTIVE DATE OF MOTION: Any aggrieved person may appeal this Conditional Use Authorization to the Board of Supervisors within thirty (30) days after the date of this Motion. The effective date of this Motion shall be the date of this Motion if not appealed (after the 30-day period has expired) OR the date of the decision of the Board of Supervisors if appealed to the Board of Supervisors. For further information, please contact the Board of Supervisors at (415) 554-5184, City Hall, Room 244, 1 Dr. Carlton B. Goodlett Place, San Francisco, CA 94102.

Protest of Fee or Exaction: You may protest any fee or exaction subject to Government Code Section 66000 that is imposed as a condition of approval by following the procedures set forth in Government Code Section 66020. The protest must satisfy the requirements of Government Code Section 66020(a) and must be filed within 90 days of the date of the first approval or conditional approval of the development referencing the challenged fee or exaction. For purposes of Government Code Section 66020, the date of imposition of the fee shall be the date of the earliest discretionary approval by the City of the subject development.

If the City has not previously given Notice of an earlier discretionary approval of the project, the Planning Commission's adoption of this Motion, Resolution, Discretionary Review Action or the Zoning Administrator's Variance Decision Letter constitutes the approval or conditional approval of the development and the City hereby gives **NOTICE** that the 90-day protest period under Government Code Section 66020 has begun. If the City has already given Notice that the 90-day approval period has begun for the subject development, then this document does not re-commence the 90-day approval period.

I hereby certify that the Planning Commission ADOPTED the foregoing Motion on January 30, 2020.

Jonas P. Ionin
Commission Secretary

AYES:

NAYS:

ABSENT:

ADOPTED: January 30, 2020

EXHIBIT A

AUTHORIZATION

his authorization is for a conditional use to the demolish an existing 3-story single family dwelling and construct a new four-story, 45-ft tall, mixed-use building with 3 dwelling units and 1,731 square feet of ground floor commercial use located at 1420 Taraval Street, Block 2353, and Lot 10 pursuant to Planning Code Section(s) 317 and 303 within the Taraval Street Neighborhood Commercial District and a 65-A Height and Bulk District; in general conformance with plans, dated January 3, 2020, and stamped "EXHIBIT B" included in the docket for Record No. 2018-011904CUA and subject to conditions of approval reviewed and approved by the Commission on January 30, 2020 under Motion No XXXXXX. This authorization and the conditions contained herein run with the property and not with a particular Project Sponsor, business, or operator.

RECORDATION OF CONDITIONS OF APPROVAL

Prior to the issuance of the building permit or commencement of use for the Project the Zoning Administrator shall approve and order the recordation of a Notice in the Official Records of the Recorder of the City and County of San Francisco for the subject property. This Notice shall state that the project is subject to the conditions of approval contained herein and reviewed and approved by the Planning Commission on January 30, 2020 under Motion No XXXXXX.

PRINTING OF CONDITIONS OF APPROVAL ON PLANS

The conditions of approval under the 'Exhibit A' of this Planning Commission Motion No. XXXXXX shall be reproduced on the Index Sheet of construction plans submitted with the site or building permit application for the Project. The Index Sheet of the construction plans shall reference to the Conditional Use authorization and any subsequent amendments or modifications.

SEVERABILITY

The Project shall comply with all applicable City codes and requirements. If any clause, sentence, section or any part of these conditions of approval is for any reason held to be invalid, such invalidity shall not affect or impair other remaining clauses, sentences, or sections of these conditions. This decision conveys no right to construct, or to receive a building permit. "Project Sponsor" shall include any subsequent responsible party.

CHANGES AND MODIFICATIONS

Changes to the approved plans may be approved administratively by the Zoning Administrator. Significant changes and modifications of conditions shall require Planning Commission approval of a new Conditional Use authorization.

Conditions of Approval, Compliance, Monitoring, and Reporting

PERFORMANCE

1. **Validity.** The authorization and right vested by virtue of this action is valid for three (3) years from the effective date of the Motion. The Department of Building Inspection shall have issued a Building Permit or Site Permit to construct the project and/or commence the approved use within this three-year period.

For information about compliance, contact Code Enforcement, Planning Department at 415-575-6863, www.sf-planning.org

2. **Expiration and Renewal.** Should a Building or Site Permit be sought after the three (3) year period has lapsed, the project sponsor must seek a renewal of this Authorization by filing an application for an amendment to the original Authorization or a new application for Authorization. Should the project sponsor decline to so file, and decline to withdraw the permit application, the Commission shall conduct a public hearing in order to consider the revocation of the Authorization. Should the Commission not revoke the Authorization following the closure of the public hearing, the Commission shall determine the extension of time for the continued validity of the Authorization.

For information about compliance, contact Code Enforcement, Planning Department at 415-575-6863, www.sf-planning.org

3. **Diligent Pursuit.** Once a site or Building Permit has been issued, construction must commence within the timeframe required by the Department of Building Inspection and be continued diligently to completion. Failure to do so shall be grounds for the Commission to consider revoking the approval if more than three (3) years have passed since this Authorization was approved.

For information about compliance, contact Code Enforcement, Planning Department at 415-575-6863, www.sf-planning.org

4. **Extension.** All time limits in the preceding three paragraphs may be extended at the discretion of the Zoning Administrator where implementation of the project is delayed by a public agency, an appeal or a legal challenge and only by the length of time for which such public agency, appeal or challenge has caused delay.

For information about compliance, contact Code Enforcement, Planning Department at 415-575-6863, www.sf-planning.org

5. **Conformity with Current Law.** No application for Building Permit, Site Permit, or other entitlement shall be approved unless it complies with all applicable provisions of City Codes in effect at the time of such approval.

For information about compliance, contact Code Enforcement, Planning Department at 415-575-6863, www.sf-planning.org

DESIGN – COMPLIANCE AT PLAN STAGE

6. **Final Materials.** The Project Sponsor shall continue to work with Planning Department on the building design. Final materials, glazing, color, texture, landscaping, and detailing shall be subject to Department staff review and approval. The architectural addenda shall be reviewed and approved by the Planning Department prior to issuance.
For information about compliance, contact the Case Planner, Planning Department at 415-558-6378, www.sf-planning.org
7. **Garbage, Composting and Recycling Storage.** Space for the collection and storage of garbage, composting, and recycling shall be provided within enclosed areas on the property and clearly labeled and illustrated on the building permit plans. Space for the collection and storage of recyclable and compostable materials that meets the size, location, accessibility and other standards specified by the San Francisco Recycling Program shall be provided at the ground level of the buildings.
For information about compliance, contact the Case Planner, Planning Department at 415-558-6378, www.sf-planning.org
8. **Rooftop Mechanical Equipment.** Pursuant to Planning Code 141, the Project Sponsor shall submit a roof plan to the Planning Department prior to Planning approval of the building permit application. Rooftop mechanical equipment, if any is proposed as part of the Project, is required to be screened so as not to be visible from any point at or below the roof level of the subject building.
For information about compliance, contact the Case Planner, Planning Department at 415-558-6378, www.sf-planning.org
9. **Streetscape Plan.** Pursuant to Planning Code Section 138.1, the Project Sponsor shall continue to work with Planning Department staff, in consultation with other City agencies, to refine the design and programming of the Streetscape Plan so that the plan generally meets the standards of the Better Streets Plan and all applicable City standards. The Project Sponsor shall complete final design of all required street improvements, including procurement of relevant City permits, prior to issuance of first architectural addenda, and shall complete construction of all required street improvements prior to issuance of first temporary certificate of occupancy.
For information about compliance, contact the Case Planner, Planning Department at 415-558-6378, www.sf-planning.org
10. **Noise.** Plans submitted with the building permit application for the approved project shall incorporate acoustical insulation and other sound proofing measures to control noise.
For information about compliance, contact the Case Planner, Planning Department at 415-558-6378, www.sf-planning.org

PARKING AND TRAFFIC

11. **Bicycle Parking.** Pursuant to Planning Code Sections 155, 155.1, and 155.2, the Project shall provide no fewer than 3 bicycle parking spaces (3 Class 1 spaces for the residential portion of the Project and 2 Class 2 spaces for the commercial portion of the Project). SFMTA has final authority on the type, placement and number of Class 2 bicycle racks within the public ROW. Prior to issuance of first architectural addenda, the project sponsor shall contact the SFMTA Bike Parking Program at bikeparking@sfmta.com to coordinate the installation of on-street bicycle racks and ensure that the proposed bicycle racks meet the SFMTA's bicycle parking guidelines. Depending on local site conditions and anticipated demand, SFMTA may request the project sponsor pay an in-lieu fee for Class II bike racks required by the Planning Code.

For information about compliance, contact Code Enforcement, Planning Department at 415-575-6863, www.sf-planning.org

12. **Managing Traffic During Construction.** The Project Sponsor and construction contractor(s) shall coordinate with the Traffic Engineering and Transit Divisions of the San Francisco Municipal Transportation Agency (SFMTA), the Police Department, the Fire Department, the Planning Department, and other construction contractor(s) for any concurrent nearby Projects to manage traffic congestion and pedestrian circulation effects during construction of the Project.

For information about compliance, contact Code Enforcement, Planning Department at 415-575-6863, www.sf-planning.org

PROVISIONS

13. **Residential Child Care Impact Fee.** The Project is subject to the Residential Child Care Fee, as applicable, pursuant to Planning Code Section 414A.

For information about compliance, contact the Case Planner, Planning Department at 415-558-6378, www.sf-planning.org

MONITORING - AFTER ENTITLEMENT

14. **Enforcement.** Violation of any of the Planning Department conditions of approval contained in this Motion or of any other provisions of Planning Code applicable to this Project shall be subject to the enforcement procedures and administrative penalties set forth under Planning Code Section 176 or Section 176.1. The Planning Department may also refer the violation complaints to other city departments and agencies for appropriate enforcement action under their jurisdiction.

For information about compliance, contact Code Enforcement, Planning Department at 415-575-6863, www.sf-planning.org

15. **Revocation due to Violation of Conditions.** Should implementation of this Project result in complaints from interested property owners, residents, or commercial lessees which are not resolved by the Project Sponsor and found to be in violation of the Planning Code and/or the specific conditions of approval for the Project as set forth in Exhibit A of this Motion, the Zoning

Administrator shall refer such complaints to the Commission, after which it may hold a public hearing on the matter to consider revocation of this authorization.

For information about compliance, contact Code Enforcement, Planning Department at 415-575-6863, www.sf-planning.org

OPERATION

16. **Sidewalk Maintenance.** The Project Sponsor shall maintain the main entrance to the building and all sidewalks abutting the subject property in a clean and sanitary condition in compliance with the Department of Public Works Streets and Sidewalk Maintenance Standards.

For information about compliance, contact Bureau of Street Use and Mapping, Department of Public Works, 415-695-2017, <http://sfdpw.org>

17. **Community Liaison.** Prior to issuance of a building permit to construct the project and implement the approved use, the Project Sponsor shall appoint a community liaison officer to deal with the issues of concern to owners and occupants of nearby properties. The Project Sponsor shall provide the Zoning Administrator and all registered neighborhood groups for the area with written notice of the name, business address, and telephone number of the community liaison. Should the contact information change, the Zoning Administrator and registered neighborhood groups shall be made aware of such change. The community liaison shall report to the Zoning Administrator what issues, if any, are of concern to the community and what issues have not been resolved by the Project Sponsor.

For information about compliance, contact Code Enforcement, Planning Department at 415-575-6863, www.sf-planning.org

18. **Lighting.** All Project lighting shall be directed onto the Project site and immediately surrounding sidewalk area only, and designed and managed so as not to be a nuisance to adjacent residents. Nighttime lighting shall be the minimum necessary to ensure safety, but shall in no case be directed so as to constitute a nuisance to any surrounding property.

For information about compliance, contact Code Enforcement, Planning Department at 415-575-6863, www.sf-planning.org

GENERAL NOTES:

INTENT OF DOCUMENTS:

It is the intent of these Contract Documents to establish a high quality of material and workmanship, but not necessarily to note and call for every last item of work to be done. Any item not specifically covered but deemed necessary for satisfactory completion of the work shall be accomplished by the Contractor in a manner consistent with the quality of the work without additional cost to the Owner. All materials and methods of installation shall be in accordance with industry standards and manufacturers recommendations.

A. All materials and workmanship shall conform to the requirements of the following codes and regulations and any other local and state laws and regulations:

- San Francisco Building Code 2016 Edition
- San Francisco Fire Code 2016 Edition
- San Francisco Plumbing Code 2016 Edition
- San Francisco Electrical Code 2016 Edition
- San Francisco Mechanical Code 2016 Edition

Verify all existing conditions and dimensions at the project site. Notify the Architect and/or Engineer of any discrepancies before beginning construction.

B. Provide adequate and proper shoring and bracing to maintain safe conditions at all times. The contractor shall be solely responsible for providing adequate shoring and bracing as required for protection of life and property during the construction of the project.

C. At all times the Contractor shall be solely and completely responsible for all conditions at the jobsite, including safety of persons and property, and all necessary independent engineering reviews of these conditions. The Architects jobsite reviews are not intended nor shall they be construed to include a review of the adequacy of the contractors safety measures.

D. Unless otherwise shown or noted, all typical details shall used where applicable.

E. All details shall be constued typical at similar conditions.

F. All Drawing conflicts shall be brought to the attention of the Architect and/or Consulting Engineer for clarification before work proceeds.

G. The Contractor shall supply all labor, materials, equipment and services, including water and power, necessary for the proper execution of the work shown on these drawings. All materials shall be new and workmanship shall be good quality. All workman and subcontractors shall be skilled in their trade. Any inspections, special or otherwise, that are required by the building codes, local builing departments, on these plans shall be done by an independent inspection company.

H. Finishes: Replace patch, repair and refinish all existing surfaces affected by the new work. All new finishes shall match the adjacent surface. all surfaces shall align.

I. The General Contractor shall visit the site and familiarize themselves with the existing site conditions prior to finalizing of any proposal to the owner. The general Contractor shall be responsible to inform the owner or Architect of potential existing conditions that need to be addressed and or modified in order to complete the work as herein described in these Drawings.

J. The General Contractor shall be reponsible for all means and methods of construction including but not limited to leveling, shimming, and blocking. The General Contractor shall make specific note of such items that can not be known prior to the commencement of construction.

.

DRAWING INDEX:

- A 1.01 SITE AND ROOF PLAN, GENERAL NOTES, AND DRAWING INDEX
- A 1.02 SITE AND ROOF PLANS EXISTING
- A 2.01 FLOOR PLANS EXISTING
- A 2.02 FLOOR PLANS PROPOSED
- A 2.03 FLOOR PLANS PROPOSED
- A 2.03 FLOOR PLANS PROPOSED
- A 3.00 EXTERIOR ELEVATIONS
- A 3.01 EXTERIOR ELEVATIONS
- A 3.02 EXTERIOR ELEVATIONS
- A 3.03 EXTERIOR ELEVATIONS
- A 3.04 EXTERIOR ELEVATIONS
- A 4.01 BUILDING SECTION
- A 4.02 BUILDING SECTION
- C-2 GREEN BUILDING FOR SITE PERMIT CIVIL SURVEY

PROJECT INFORMATION:

ZONING: NCD TARAVAL NEIGHBORHOOD COMMERCIAL DISTRICT

OCCUPANCY R-3
EXISTING USE: 1 FAMILY RESIDENCE
PROPOSED USE: THREE RESIDENTIAL UNITS OVER COMMERCIAL SPACE

PROPOSED BUILDING HEIGHT: 45'-4"

PROPOSED 4 STORIES

CONSTRUCTION TYPE: 3-A

BUILDING TO BE FIRE SPRINKLERED NFPA-13 R WORK BY SEPERATE PERMIT

BLOCK 2353 LOT 010

SCOPE OF WORK:
NEW 3 UNIT RESIDENTIAL BUILDING

PROJECT STATISTICS

PROPOSED	COMMON	RESIDENTIAL	COMMERCIAL	TOTAL
1ST FLOOR:	759 SF	0 SF	1,713 SF	2,472 SF
2ND FLOOR:	241 SF	1,604 SF	0 SF	1,845 SF
3RD FLOOR:	238 SF	1,580 SF	0 SF	1,818 SF
4TH FLOOR:	238 SF	1,634 SF	0 SF	1,872 SF
ROOF:	202 SF	0 SF	0 SF	202 SF
TOTAL	1,668 SF	4,818 SF	1,713 SF	8,209 SF

UNIT 1	1,604 SF
UNIT 2	1,580 SF
UNIT 3	1,634 SF

OPEN SPACE:

REQUIRED OPEN SPACE EA UNIT 300 SF

UNIT 1	558 SF
UNIT 2	56 SF AT UNIT: REQUIRED OPEN SPACE PROVIDED AT ROOF DECK
UNIT 3	0 SF AT UNIT: OPEN SPACE PROVIDED AT ROOF DECK
ROOF	778 SF: DECK OPEN TO UNIT 2 AND 3

BIKE PARKING

3 CLASS A SPACES PROVIDED
SEE A 2.02 1ST FLOOR PLAN

ABBREVIATIONS:

@	AT	HGT./HT.	HEIGHT
CL	CENTERLINE		
Ø	DIAMETER OR ROUND	INSUL.	INSULATION
(E)	EXISTING		
(N)	NEW	MF6.	MANUFACTURING
(R)	REPLACE	MAX.	MAXIMUM
		MTL.	METAL
		MIN.	MINIMUM
AFF	ABOVE FINISH FLOOR	O.C.	ON CENTER
BM.	BEAM		
BLDG.	BUILDING	PR.	PAIR
		PKT.	POCKET
		P.T.	PRESSURE TREATED
CBC	CALIFORNIA BUILDING CODE	REF.	REFRIGERATOR
CLR.	CLEAR	REQ'D	REQUIRED
CLOS.	CLOSET	REQ'T	REQUIREMENT
CONC.	CONCRETE	RTG.	RETAINING
		R & S	ROD AND SHELF
		RM.	ROOM
DECK'G	DECKING		
DET.	DETAIL	SIM.	SIMILAR
DIA.	DIAMETER	S.C.	SOLID CORE
DISP.	DISPOSAL	SQ. FT.	SQUARE FOOT/FEET
DW.	DISHWASHER	STOR.	STORAGE
DR.	DOOR	STRUCT.	STRUCTURAL
DBL.	DOUBLE		
DN.	DOWN	TEMP.	TEMPERED
DRWGS.	DRAWINGS	TRANS.	TRANSPARENT
D	DRYER	TYP.	TYPICAL
EA.	EACH	U.O.N.	UNLESS OTHERWISE NOTED
F	FAHRENHEIT		
FIN.	FINISH		
F.R.	FIRE RATED	V.I.F.	VERIFY IN FIELD
FLR.	FLOOR		
FT.	FOOT OR FEET	W	WASHER
FR.	FRENCH	WH.	WATER HEATER
FURN.	FURNISH	WP	WATERPROOF
FURR.	FURRING	WDO.	WINDOW
		W/	WITH
		WD.	WOOD
GA.	GAUGE		
GL.	GLAZING		
GYP.	GYP SUM		
GYP.BD.	GYP SUM BOARD		

DRAWING SYMBOLS

- DOOR NUMBER
- WINDOW NUMBER
- SKYLIGHT NUMBER
- DRAWING REVISION
- DETAIL NUMBER AND DRAWING REFERENCE
- NOTE/ITEM NUMBER
- 0'-0" GRADE
- PL- PROPERTY LINE
- ELEV. NO. DRAWING REFERENCE

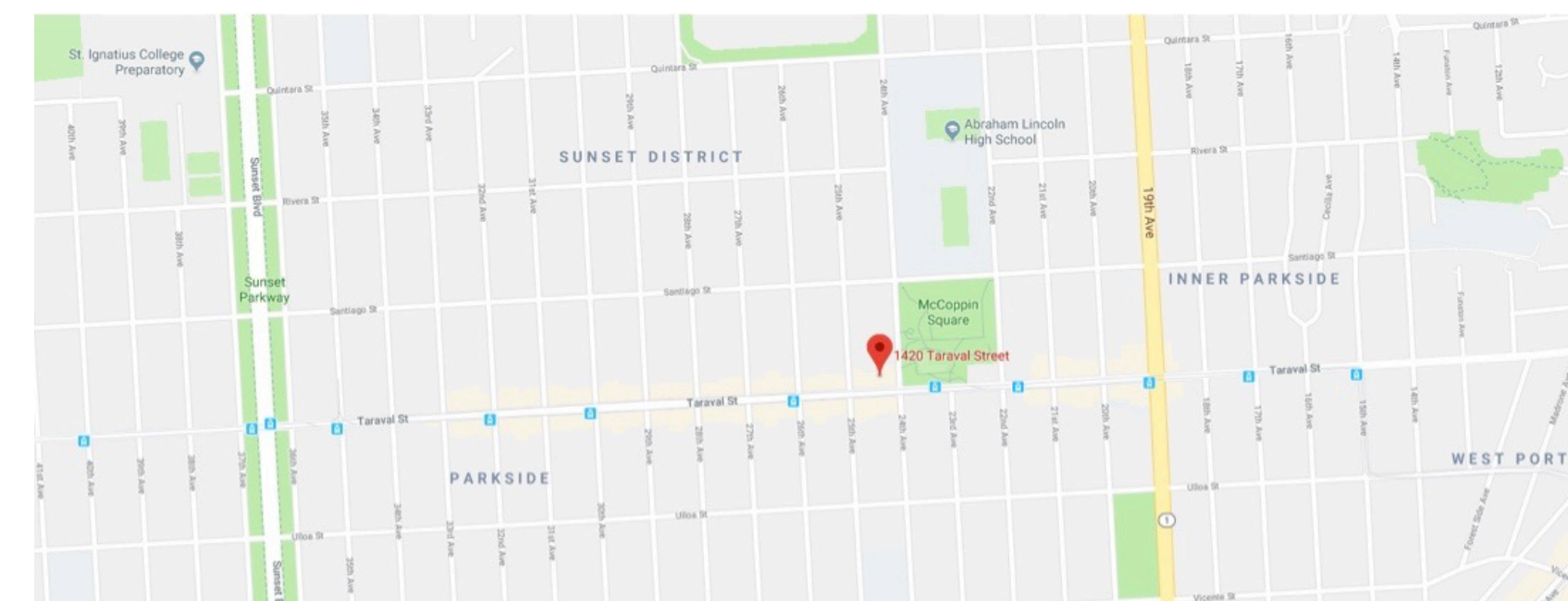

VIICINITY MAP

WILLIAM PASHELINSKY ARCHITECT

1937 HAYES STREET
SAN FRANCISCO, CA.94117
415.379.9876
billpash@gmail.com

NEW 3 UNIT RESIDENCE OVER COMMERCIAL SPACE

1420 TARAVAL STREET
SAN FRANCISCO, CA.

ALL IDEAS, DESIGNS, ARRANGEMENTS AND PLANS AS INDICATED OR REPRESENTED BY THIS DRAWING ARE OWNED BY AND ARE THE PROPERTY OF WILLIAM PASHELINSKY ARCHITECT AND WERE CREATED, EVOLVED AND DEVELOPED FOR USE ON, AND IN CONNECTION WITH THIS SPECIFIC PROJECT. NONE OF THESE IDEAS, DESIGNS, ARRANGEMENTS OF PLANS SHALL BE USED BY OR DISCLOSED TO ANY PERSON, FIRM, OR CORPORATION FOR ANY PURPOSE WHATSOEVER WITHOUT THE WRITTEN PERMISSION OF WILLIAM PASHELINSKY ARCHITECT

NO.	DATE	DESCRIPTION
2	11.7/19	PLANNING REV
4	01.03.20	PLANNING REV

PROJECT NO. 2017.33
SHEET

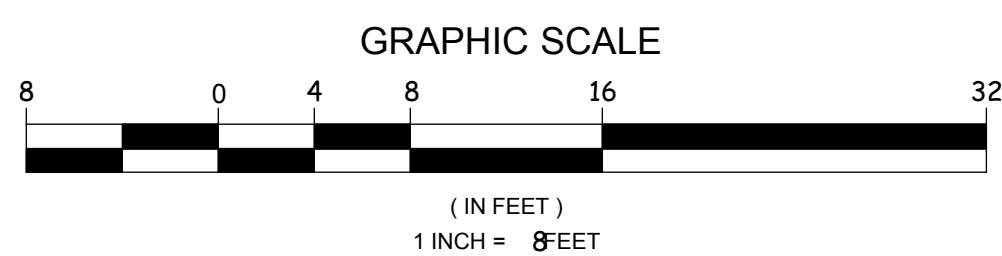
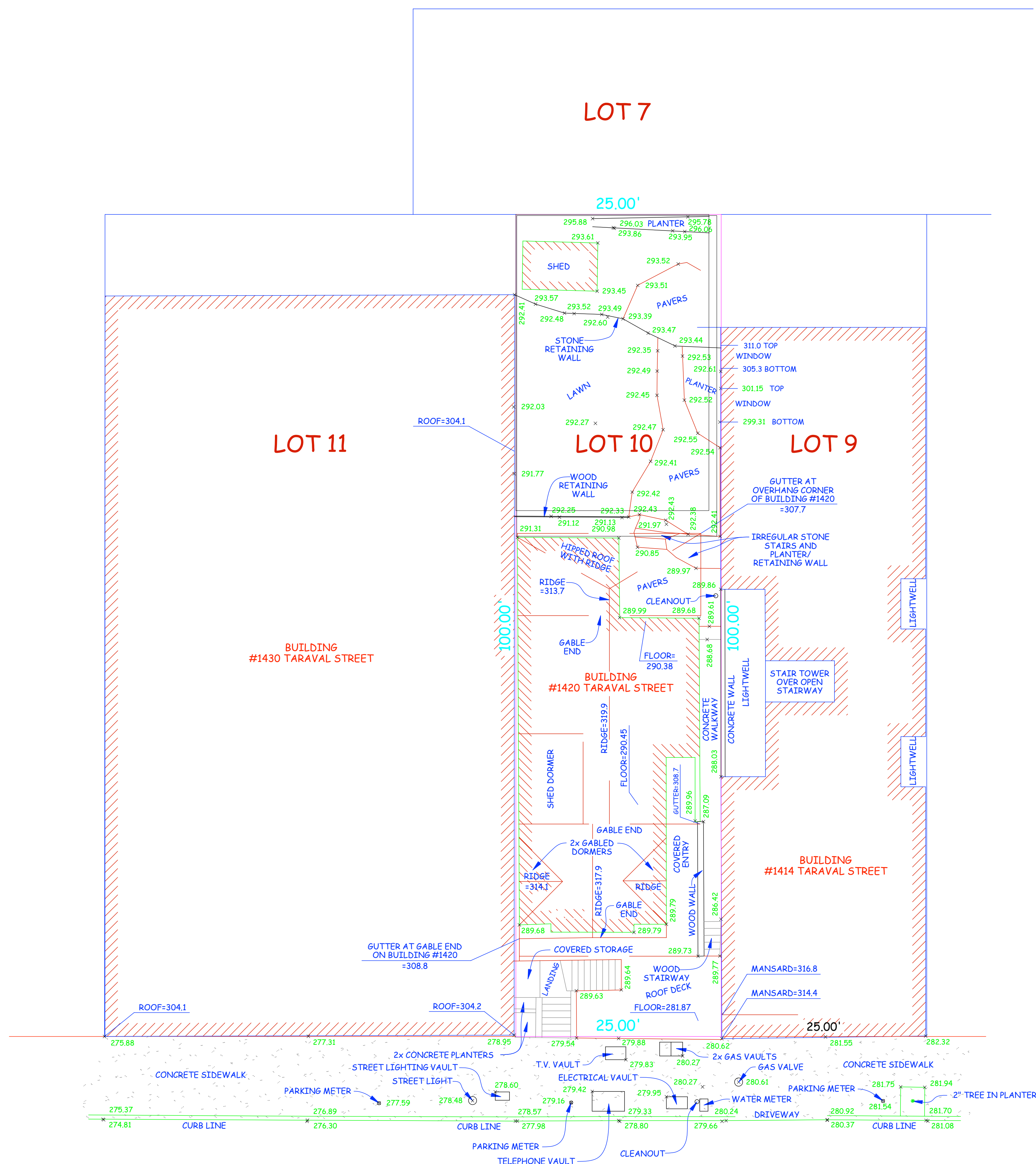

SITE PLAN (E)
 1/8"=1'-0"

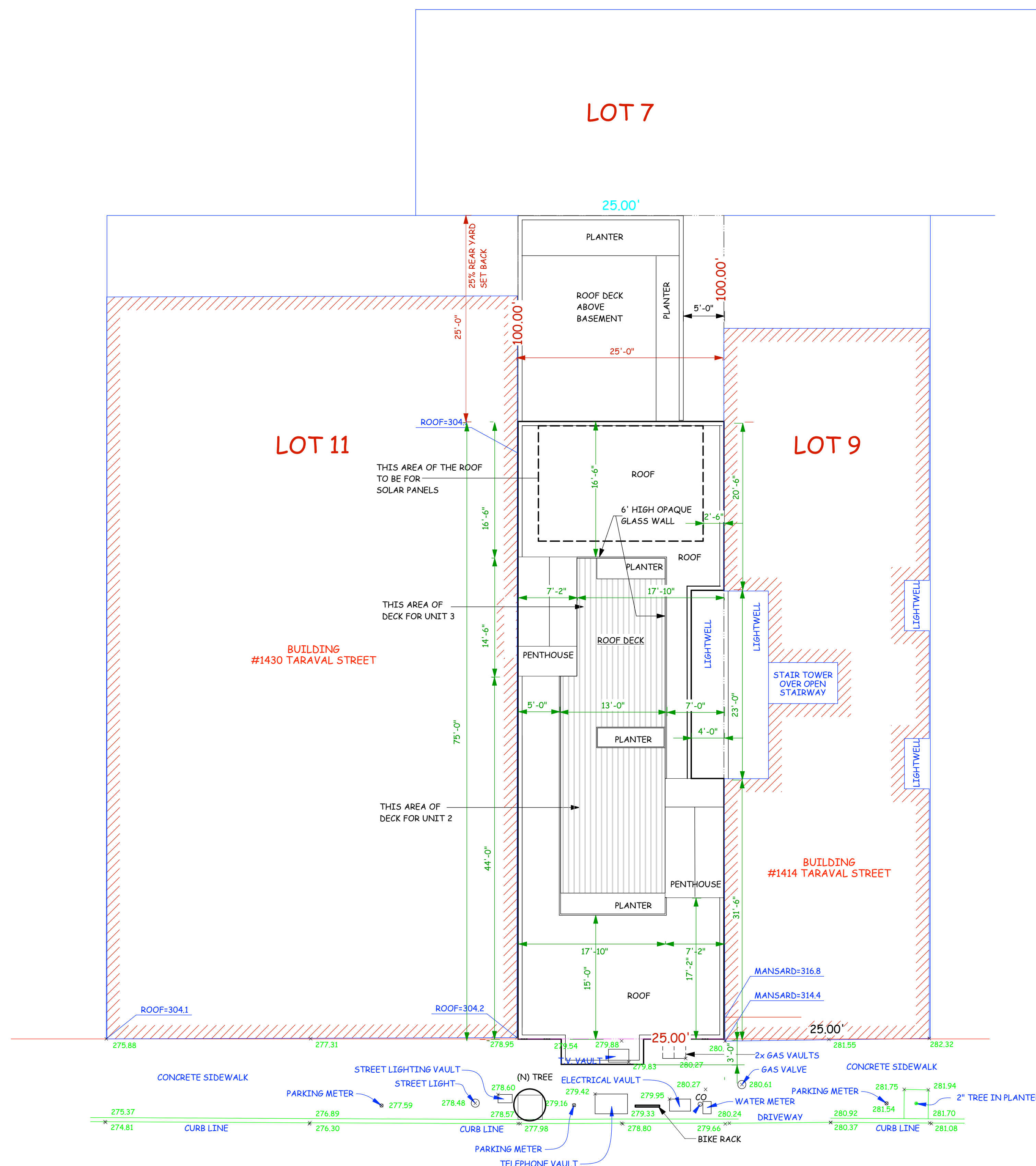

SITE PLAN (N)
 1/8"=1'-0"

ALL IDEAS, DESIGNS, ARRANGEMENTS AND PLANS AS INDICATED OR REPRESENTED BY THIS DRAWING ARE OWNED BY AND ARE THE PROPERTY OF WILLIAM PASHELINSKY ARCHITECT AND WERE CREATED, EVOLVED AND DEVELOPED FOR USE ON, AND IN CONNECTION WITH THIS SPECIFIC PROJECT. NONE OF THESE IDEAS, DESIGNS, ARRANGEMENTS OF PLANS SHALL BE USED BY OR DISCLOSED TO ANY PERSON, FIRM, OR CORPORATION FOR ANY PURPOSE WHATSOEVER WITHOUT THE WRITTEN PERMISSION OF WILLIAM PASHELINSKY ARCHITECT

NO.	DATE	DESCRIPTION
1	05.15.19	PLANNING REV
4	01.03.20	PLANNING REV

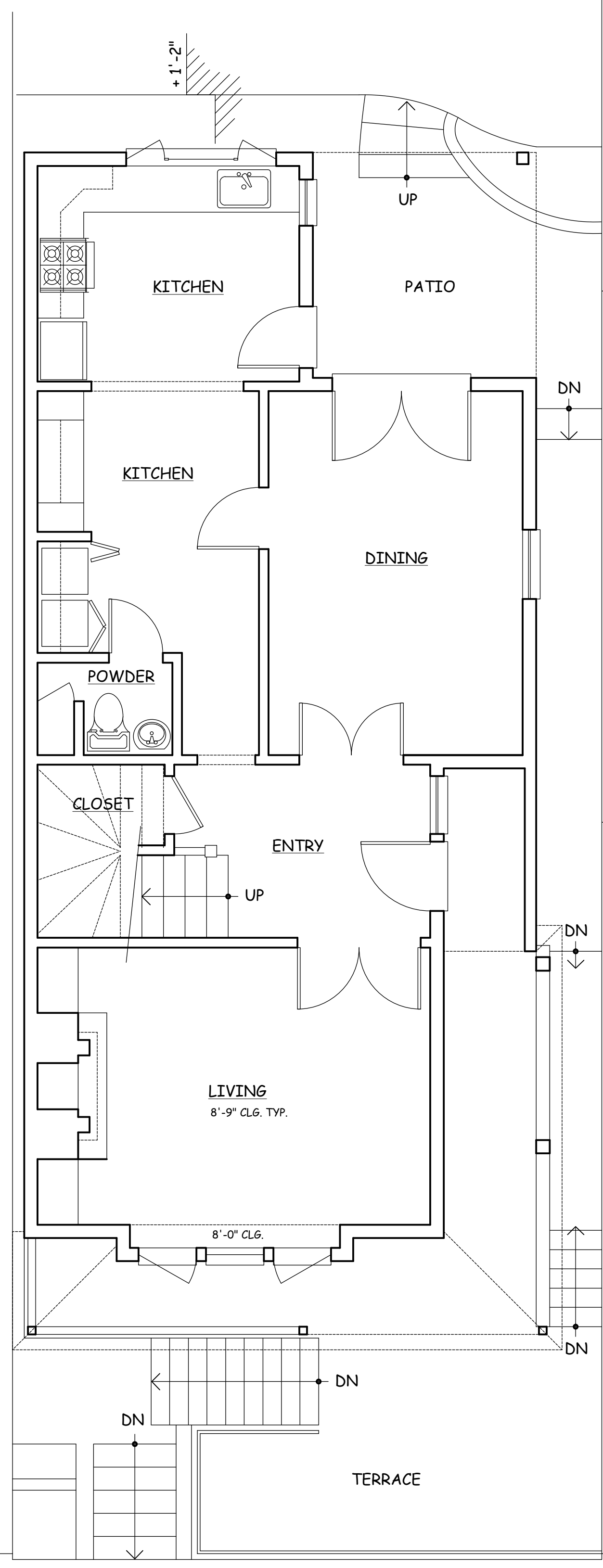

1ST FLOOR PLAN (E)
 1/4"=1'-0"

EXISTING BUILDING STATS

1ST FLOOR:	865 SF
2ND FLOOR:	986 SF
3RD FLOOR:	325 SF
TOTAL:	2,176 SF

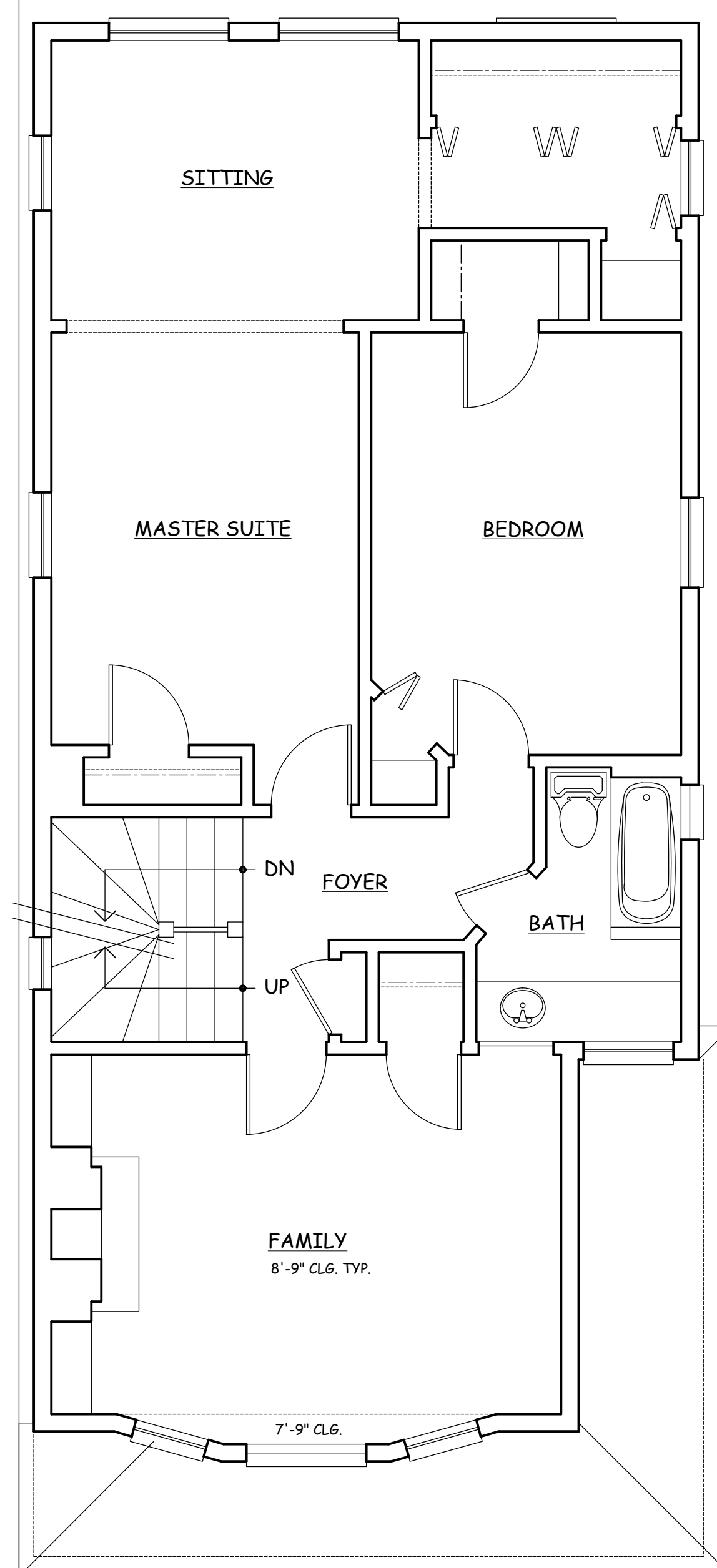

2ND FLOOR PLAN (E)
 1/4"=1'-0"

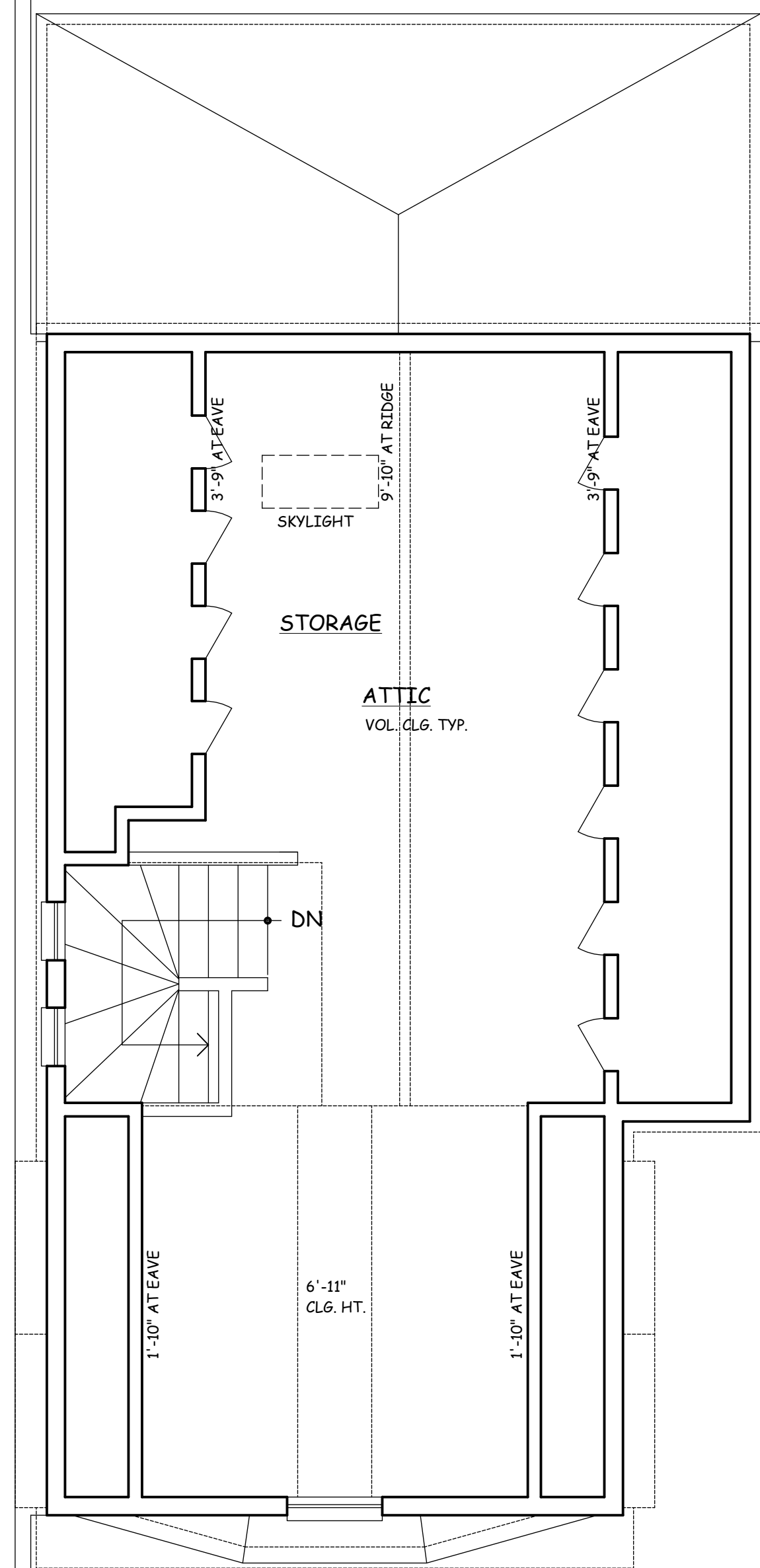

3RD FLOOR PLAN (E)
 1/4"=1'-0"

(E) BUILDING TO BE DEMOLISHED

ALL IDEAS, DESIGNS, ARRANGEMENTS AND PLANS AS INDICATED OR REPRESENTED BY THIS DRAWING ARE OWNED BY AND ARE THE PROPERTY OF WILLIAM PASHELINSKY ARCHITECT AND WERE CREATED, EVOLVED AND DEVELOPED FOR USE ON, AND IN CONNECTION WITH THIS SPECIFIC PROJECT. NONE OF THESE IDEAS, DESIGNS, ARRANGEMENTS OF PLANS SHALL BE USED BY OR DISCLOSED TO ANY PERSON, FIRM, OR CORPORATION FOR ANY PURPOSE WHATSOEVER WITHOUT THE WRITTEN PERMISSION OF WILLIAM PASHELINSKY ARCHITECT

NO.	DATE	DESCRIPTION

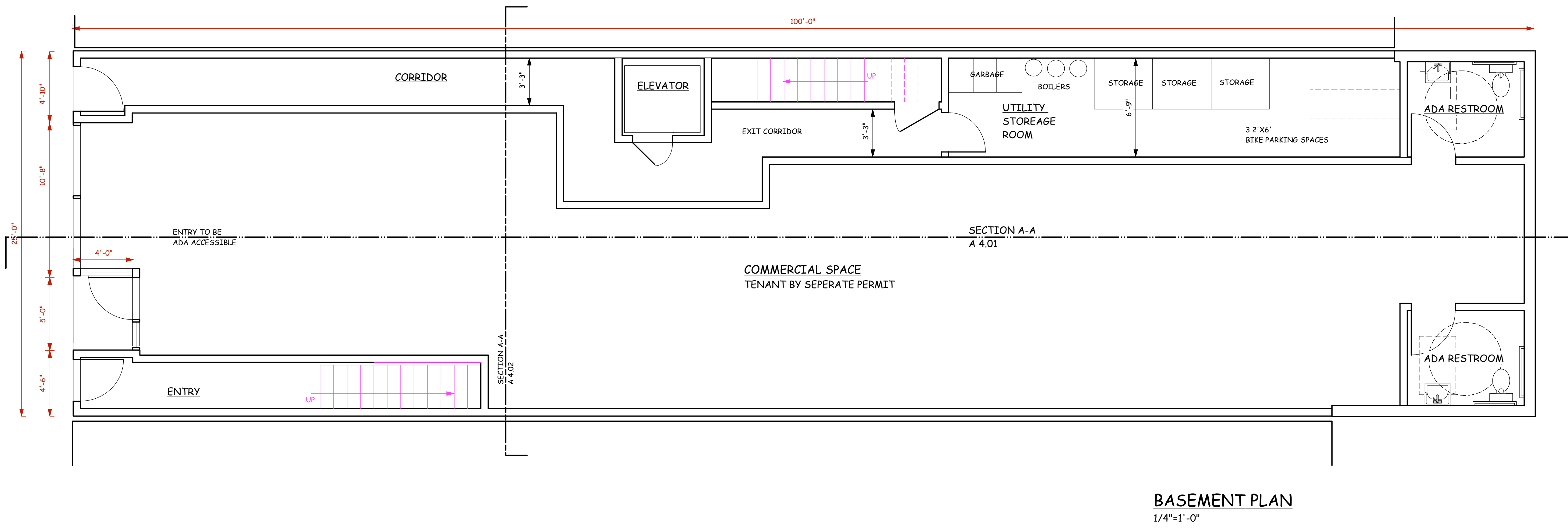
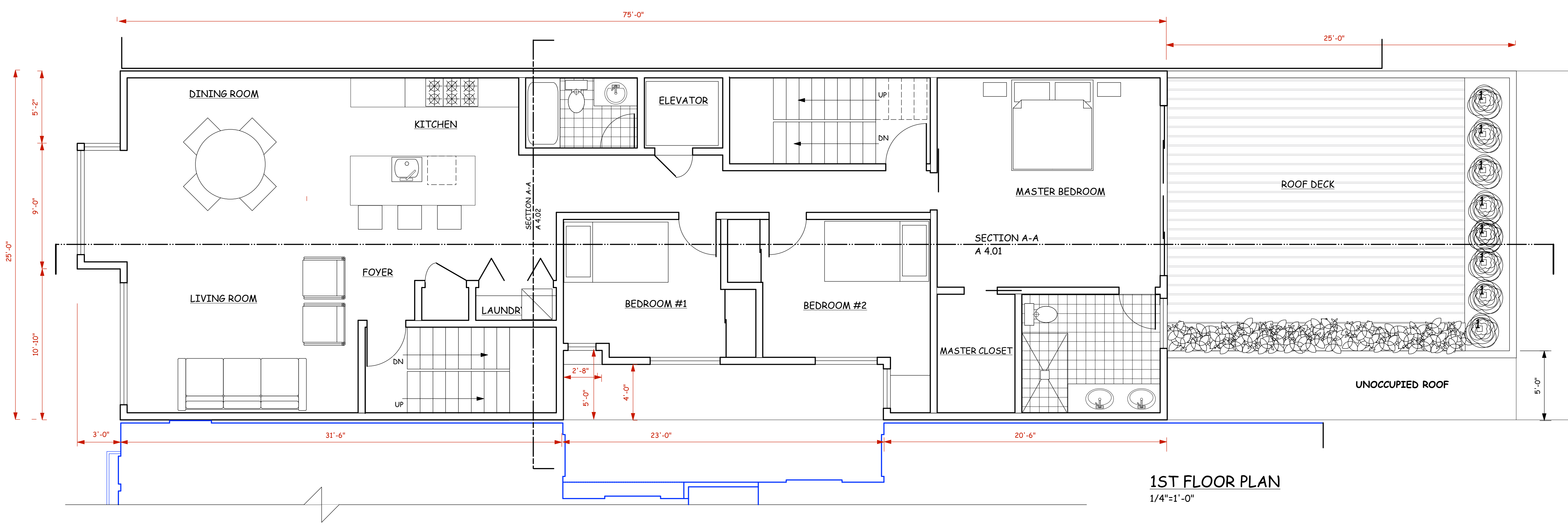

ALL IDEAS, DESIGNS, ARRANGEMENTS AND PLANS AS INDICATED OR REPRESENTED BY THIS DRAWING ARE OWNED BY AND ARE THE PROPERTY OF WILLIAM PASHELINSKY ARCHITECT AND WERE CREATED, EVOLVED AND DEVELOPED FOR USE ON, AND IN CONNECTION WITH THIS SPECIFIC PROJECT. NONE OF THESE IDEAS, DESIGNS, ARRANGEMENTS OF PLANS SHALL BE USED BY OR DISCLOSED TO ANY PERSON, FIRM, OR CORPORATION FOR ANY PURPOSE WHATSOEVER WITHOUT THE WRITTEN PERMISSION OF WILLIAM PASHELINSKY ARCHITECT

NO.	DATE	DESCRIPTION
1	05.15.19	PLANNING REV
4	01.03.20	PLANNING REV

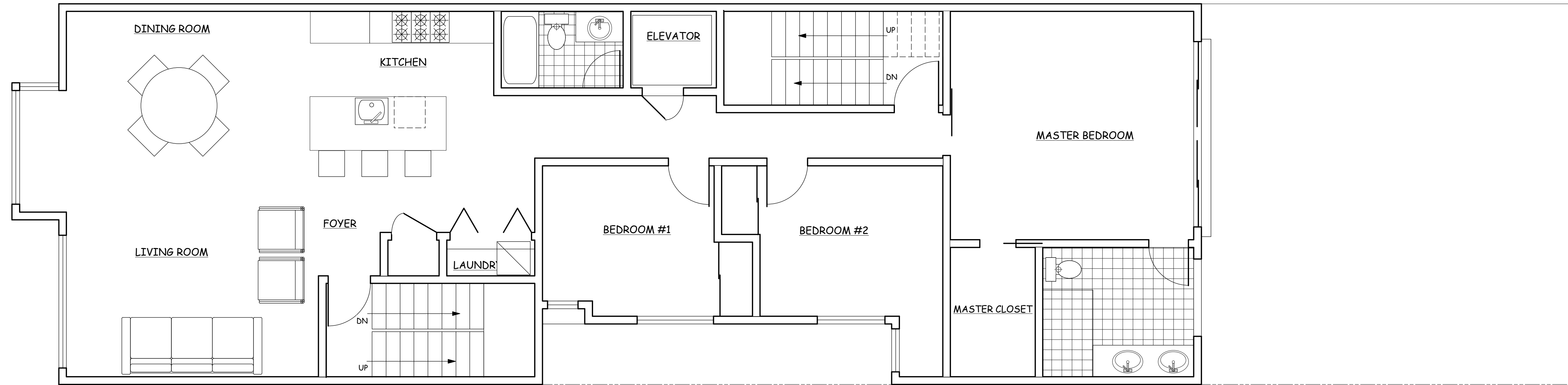

3RD FLOOR PLAN
1/4"=1'-0"

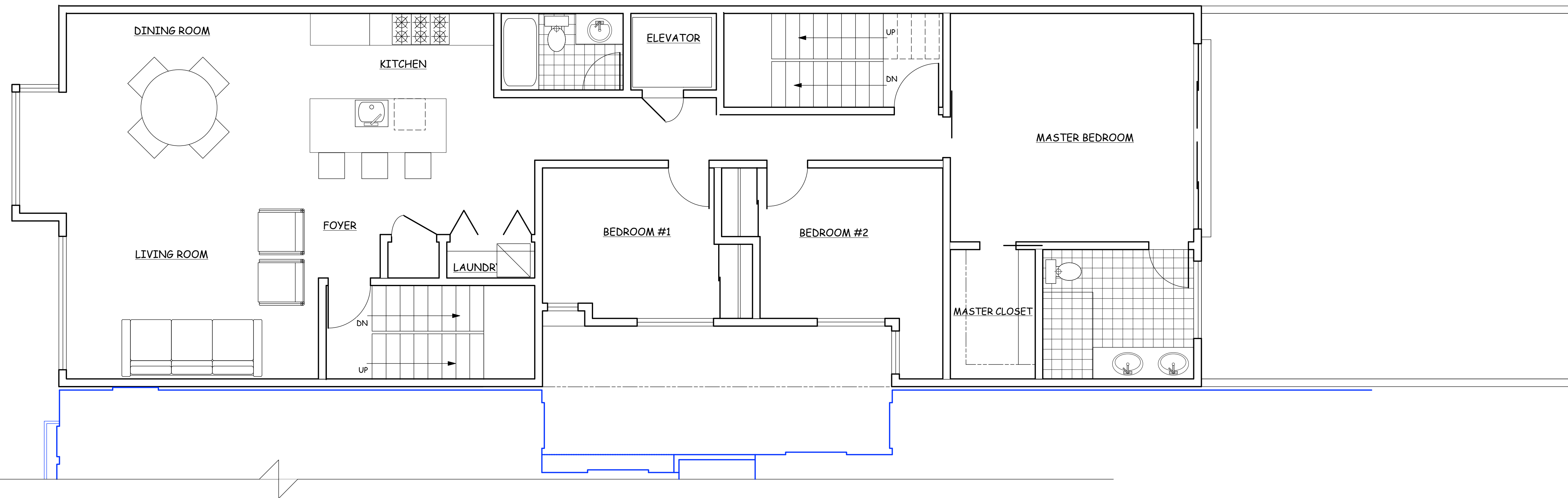

2ND FLOOR PLAN
1/4"=1'-0"

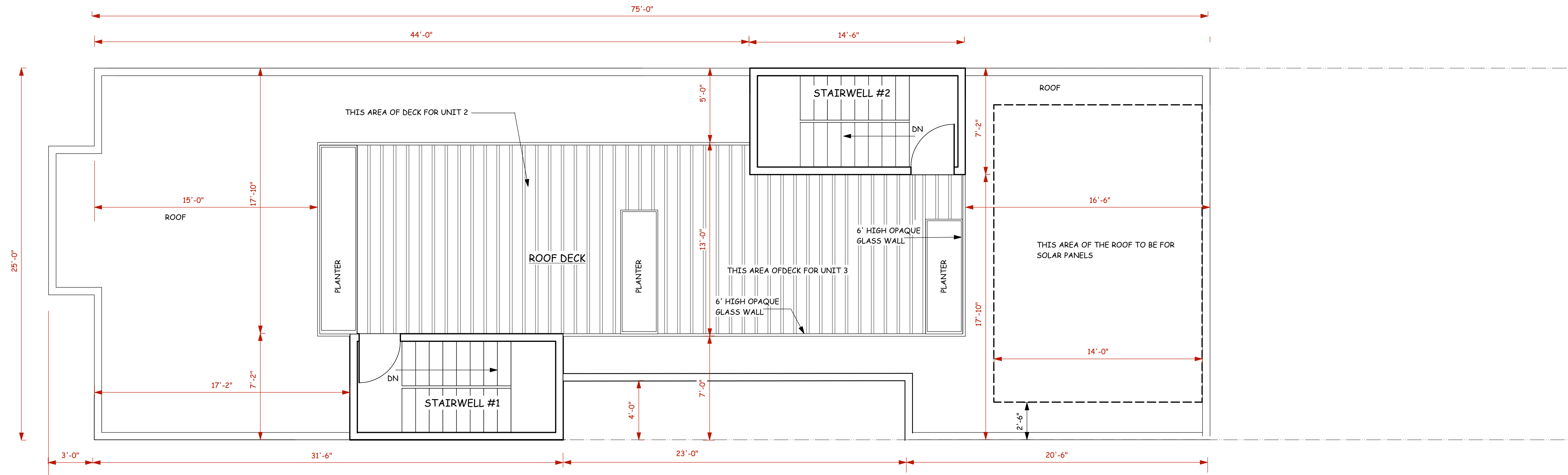

ROOF PLAN
 1/4"=1'-0"

ROOF 1: 1,870 S.F.
 STAIR PENTHOUSES: 206 S.F.
 ALLOWABLE 1,870X.2= 374 S.F.

PER BETTER ROOF ORDINANCE
 SOLAR PANELS TO BE PROVIDED
 1,870X.15= 280 S.F.

ALL IDEAS, DESIGNS, ARRANGEMENTS AND PLANS AS INDICATED OR REPRESENTED BY THIS DRAWING ARE OWNED BY AND ARE THE PROPERTY OF WILLIAM PASHELINSKY ARCHITECT AND WERE CREATED, EVOLVED AND DEVELOPED FOR USE ON, AND IN CONNECTION WITH THIS SPECIFIC PROJECT. NONE OF THESE IDEAS, DESIGNS, ARRANGEMENTS OF PLANS SHALL BE USED BY OR DISCLOSED TO ANY PERSON, FIRM, OR CORPORATION FOR ANY PURPOSE WHATSOEVER WITHOUT THE WRITTEN PERMISSION OF WILLIAM PASHELINSKY ARCHITECT

NO.	DATE	DESCRIPTION
1	05.15.19	PLANNING REV
4	01.03.20	PLANNING REV



ALL IDEAS, DESIGNS, ARRANGEMENTS AND PLANS AS INDICATED OR REPRESENTED BY THIS DRAWING ARE OWNED BY AND ARE THE PROPERTY OF WILLIAM PASHELINSKY ARCHITECT AND WERE CREATED, EVOLVED AND DEVELOPED FOR USE ON, AND IN CONNECTION WITH THIS SPECIFIC PROJECT. NONE OF THESE IDEAS, DESIGNS, ARRANGEMENTS OF PLANS SHALL BE USED BY OR DISCLOSED TO ANY PERSON, FIRM, OR CORPORATION FOR ANY PURPOSE WHATSOEVER WITHOUT THE WRITTEN PERMISSION OF WILLIAM PASHELINSKY ARCHITECT.

NO.	DATE	DESCRIPTION
1	05.15.19	PLANNING REV

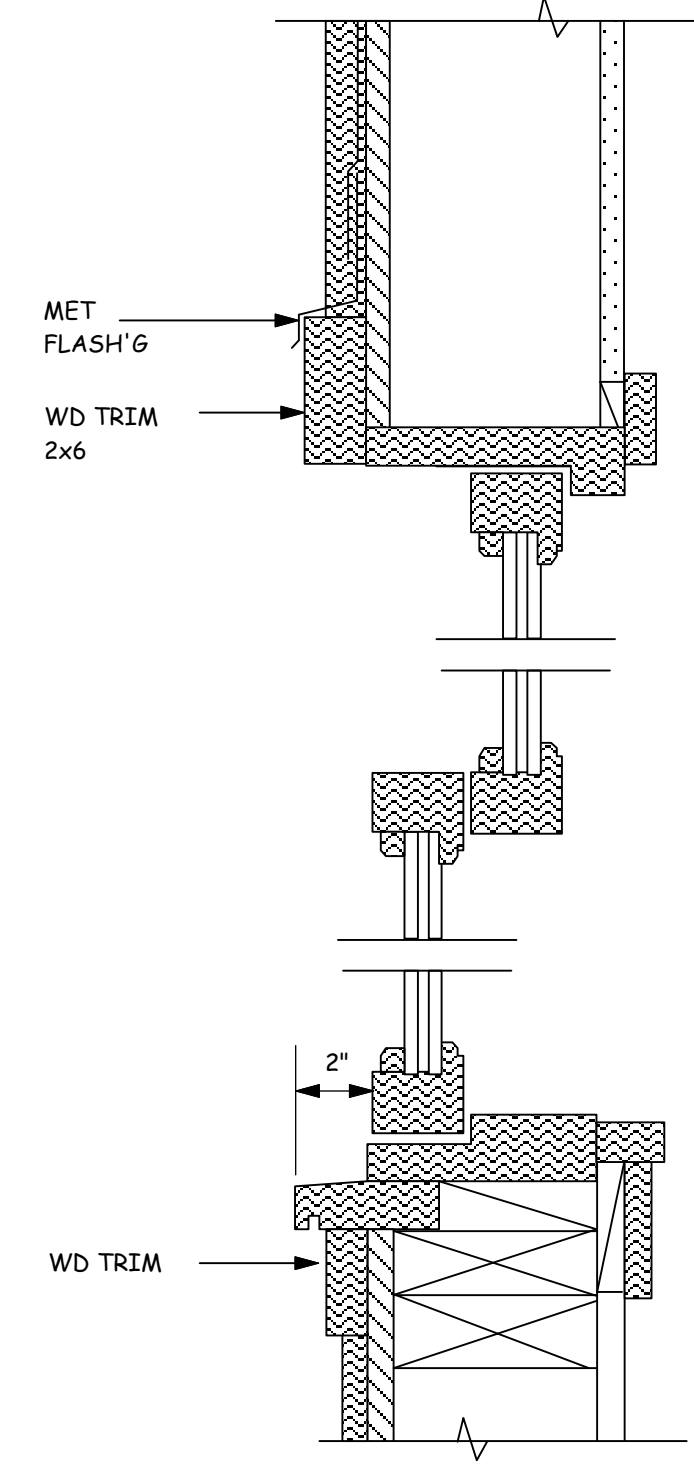

1 TYP WINDOW DET DBL HUNG

MARVIN ALUM
 CLAD WINDOW
 TYP AT FRONT
 NOTE: ALL WINDOWS AT FRONT ELEVATION
 AND WEST TO BE ALUM CLAD

ALL IDEAS, DESIGNS, ARRANGEMENTS AND PLANS AS INDICATED OR REPRESENTED BY THIS DRAWING ARE OWNED BY AND ARE THE PROPERTY OF WILLIAM PASHELINSKY ARCHITECT AND WERE CREATED, EVOLVED AND DEVELOPED FOR USE ON, AND IN CONNECTION WITH THIS SPECIFIC PROJECT. NONE OF THESE IDEAS, DESIGNS, ARRANGEMENTS OF PLANS SHALL BE USED BY OR DISCLOSED TO ANY PERSON, FIRM, OR CORPORATION FOR ANY PURPOSE WHATSOEVER WITHOUT THE WRITTEN PERMISSION OF WILLIAM PASHELINSKY ARCHITECT

NO.	DATE	DESCRIPTION
1	05.15.19	PLANNING REV
2	06.10.19	PLANNING REV
3	21.21.19	PLANNING REV
4	01.03.20	PLANNING REV

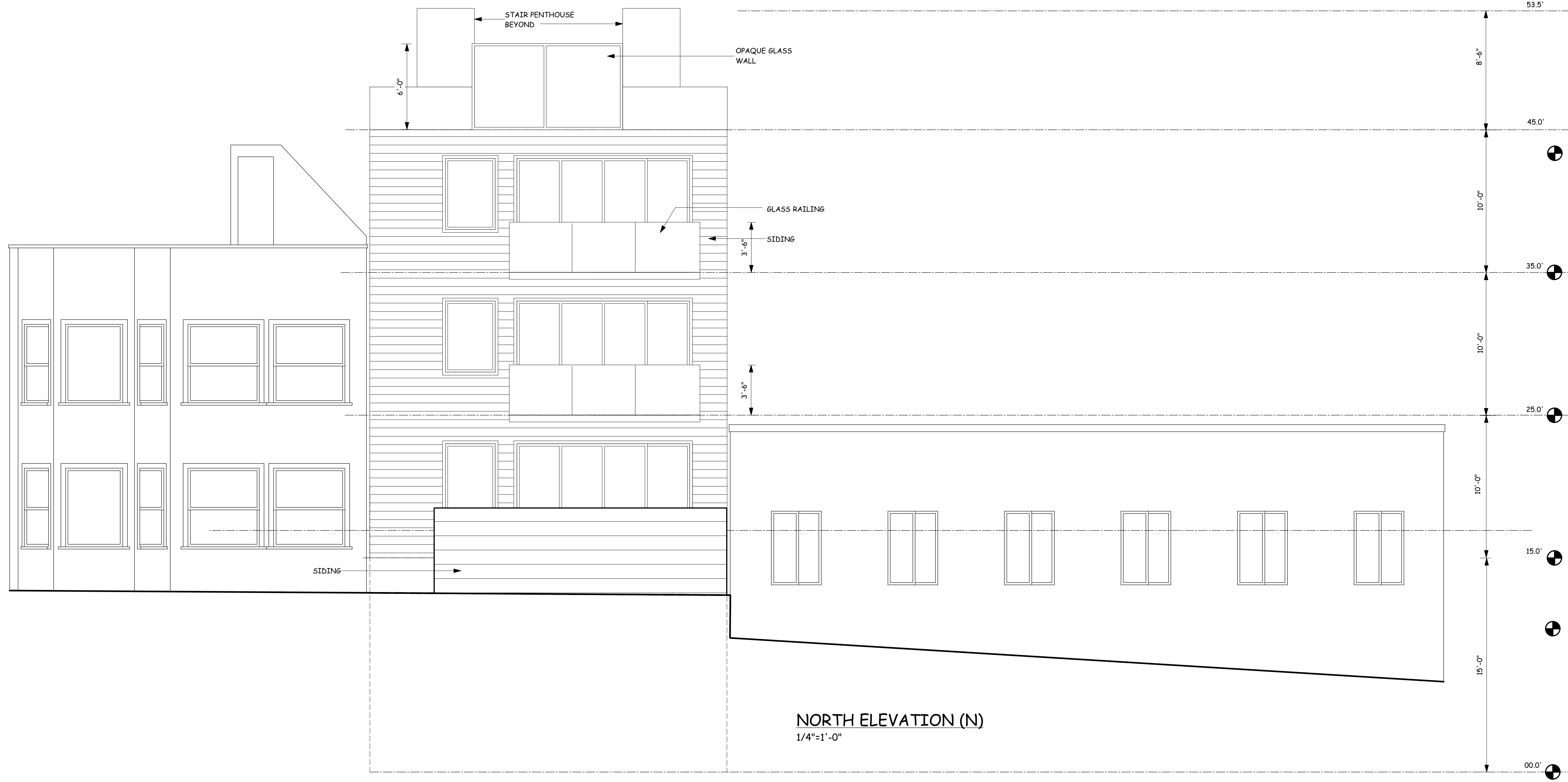

NORTH ELEVATION (N)
1/4"=1'-0"



NORTH ELEVATION (E)
1/4"=1'-0"

WILLIAM PASHELINSKY ARCHITECT
1837 HAYES STREET
SAN FRANCISCO, CA 94117
415 379 3676
billpash@gmail.com

NEW 3 UNIT RESIDENCE OVER COMMERCIAL SPACE
1420 TARAVAL STREET
SAN FRANCISCO, CA

ALL IDEAS, DESIGNS, ARRANGEMENTS AND PLANS AS INDICATED OR REPRESENTED BY THIS DRAWING ARE OWNED BY AND ARE THE PROPERTY OF WILLIAM PASHELINSKY ARCHITECT AND WERE CREATED, EVOLVED AND DEVELOPED FOR USE ON, AND IN CONNECTION WITH THIS SPECIFIC PROJECT. NONE OF THESE IDEAS, DESIGNS, ARRANGEMENTS OF PLANS SHALL BE USED BY OR DISCLOSED TO ANY PERSON, FIRM, OR CORPORATION FOR ANY PURPOSE WHATSOEVER WITHOUT THE WRITTEN PERMISSION OF WILLIAM PASHELINSKY ARCHITECT

NO.	DATE	DESCRIPTION
1	05.15.19	PLANNING REV
3	01.03.19	PLANNING REV

PROJECT NO. 2017.32
SHEET

A-3.02



EAST ELEVATION (N)
 1/4"=1'-0"

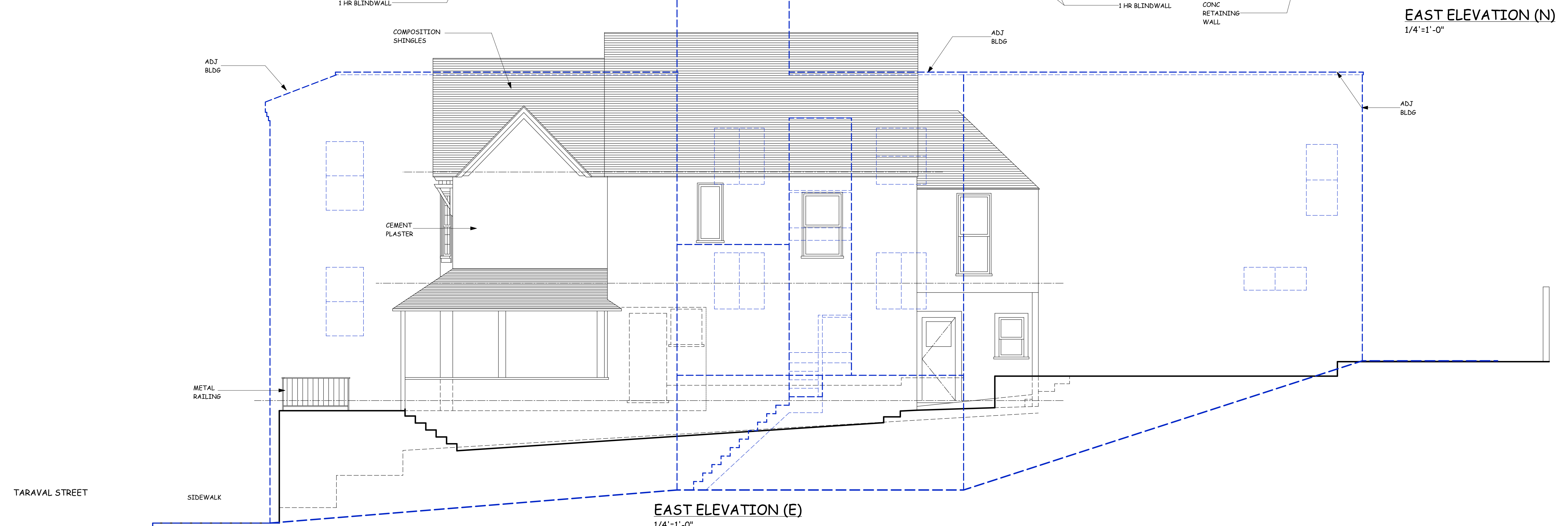

EAST ELEVATION (E)
 1/4"=1'-0"

ALL IDEAS, DESIGNS, ARRANGEMENTS AND PLANS AS INDICATED OR REPRESENTED BY THIS DRAWING ARE OWNED BY AND ARE THE PROPERTY OF WILLIAM PASHELINSKY ARCHITECT AND WERE CREATED, EVOLVED AND DEVELOPED FOR USE ON, AND IN CONNECTION WITH THIS SPECIFIC PROJECT. NONE OF THESE IDEAS, DESIGNS, ARRANGEMENTS, OR PLANS SHALL BE USED BY OR DISCLOSED TO ANY PERSON, FIRM, OR CORPORATION FOR ANY PURPOSE WHATSOEVER WITHOUT THE WRITTEN PERMISSION OF WILLIAM PASHELINSKY ARCHITECT.

NO.	DATE	DESCRIPTION
1	05.15.19	PLANNING REV
2	10.21.19	PLANNING REV
3	01.03.19	PLANNING REV

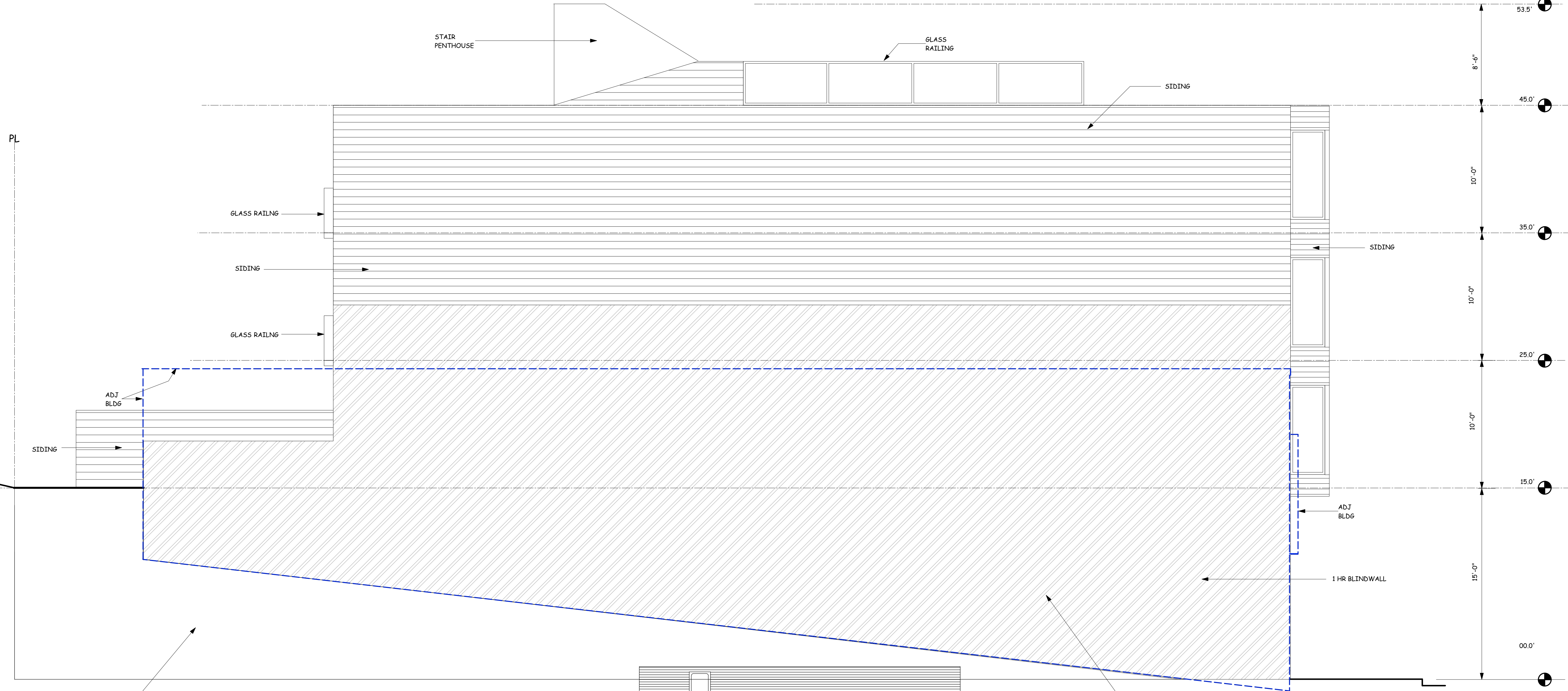

WEST ELEVATION (N)
 1/4"=1'-0"

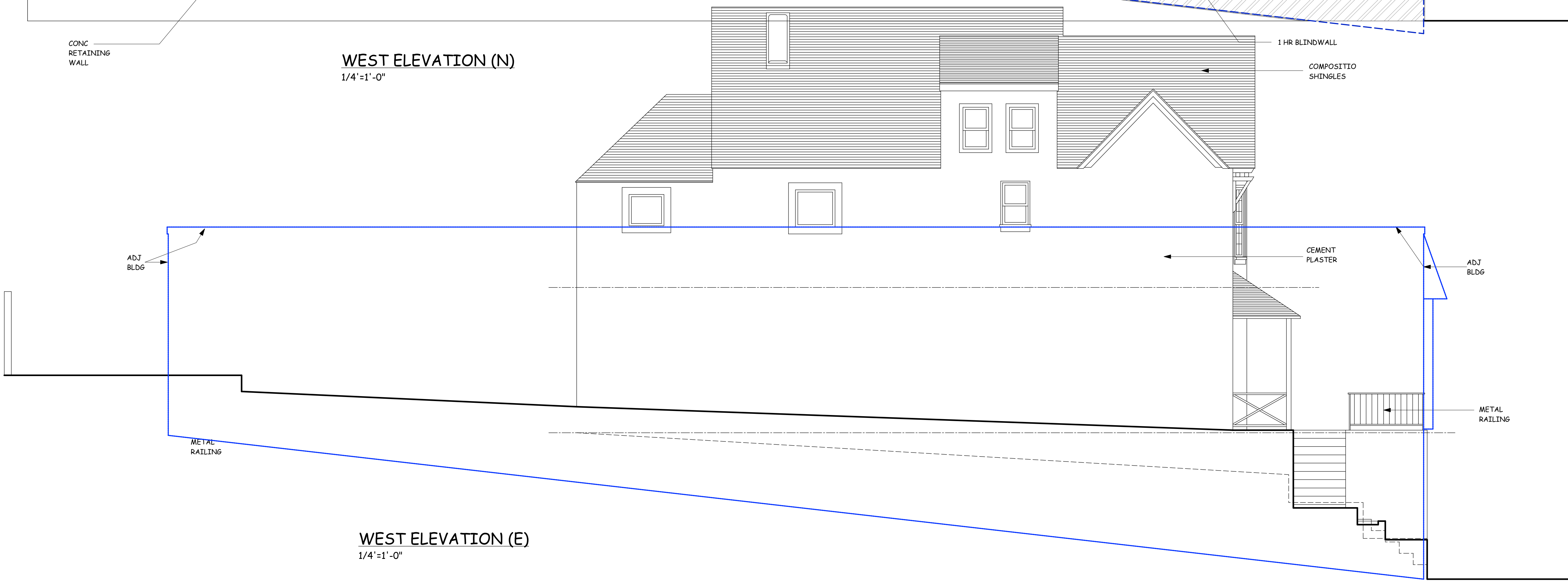

WEST ELEVATION (E)
 1/4"=1'-0"

ALL IDEAS, DESIGNS, ARRANGEMENTS AND PLANS AS INDICATED OR REPRESENTED BY THIS DRAWING ARE OWNED BY AND ARE THE PROPERTY OF WILLIAM PASHELINSKY ARCHITECT AND WERE CREATED, EVOLVED AND DEVELOPED FOR USE ON, AND IN CONNECTION WITH THIS SPECIFIC PROJECT. NONE OF THESE IDEAS, DESIGNS, ARRANGEMENTS OF PLANS SHALL BE USED BY OR DISCLOSED TO ANY PERSON, FIRM, OR CORPORATION FOR ANY PURPOSE WHATSOEVER WITHOUT THE WRITTEN PERMISSION OF WILLIAM PASHELINSKY ARCHITECT

NO.	DATE	DESCRIPTION
1	05.15.19	PLANNING REV
2	10.21.19	PLANNING REV
3	01.03.19	PLANNING REV

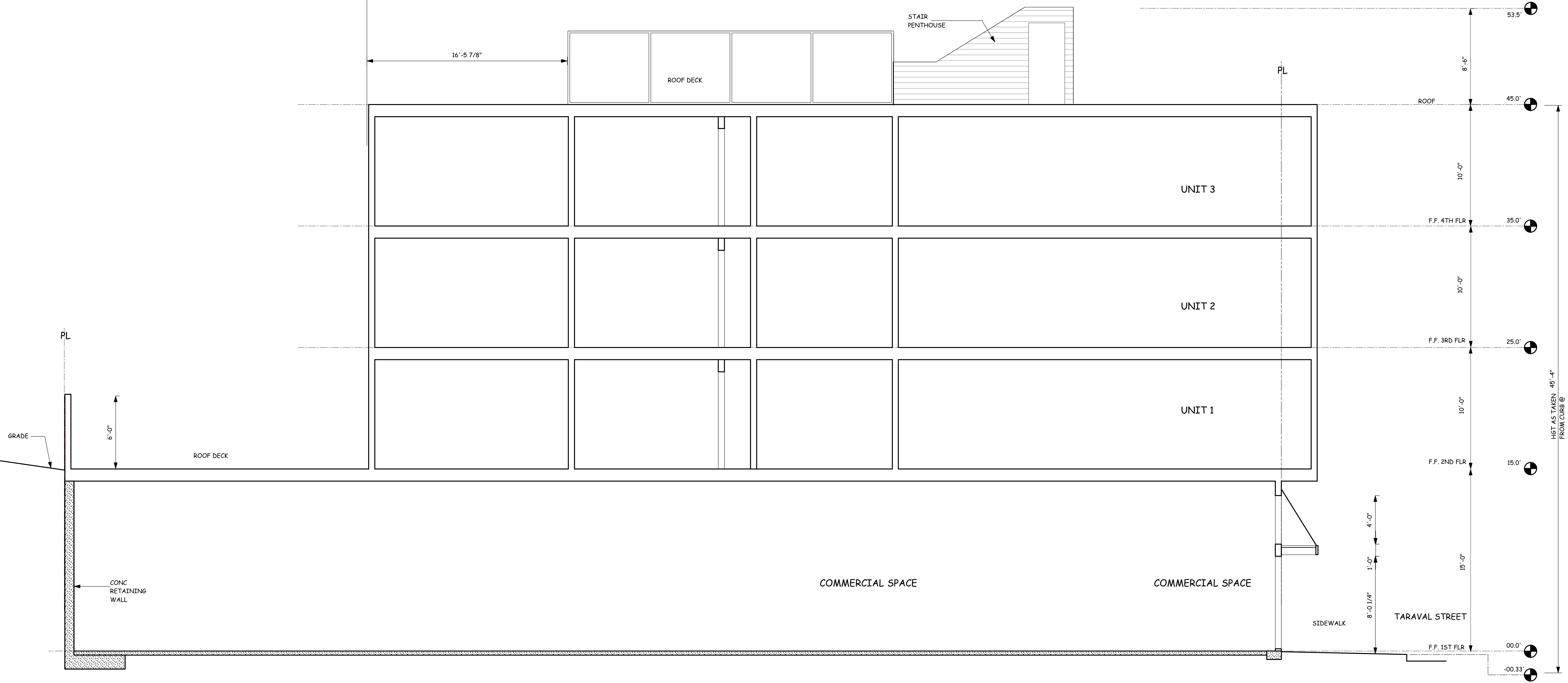

SECTION A-A (N)
1/4"=1'-0"

WILLIAM PASHELINSKY ARCHITECT
1837 HAYES STREET
SAN FRANCISCO, CA 94117
415 379 8676
billpash@gmail.com

NEW 3 UNIT RESIDENCE OVER COMMERCIAL SPACE
1420 TARAVAL STREET
SAN FRANCISCO, CA

ALL IDEAS, DESIGNS, ARRANGEMENTS AND PLANS AS INDICATED OR REPRESENTED BY THIS DRAWING ARE OWNED BY AND ARE THE PROPERTY OF WILLIAM PASHELINSKY ARCHITECT AND WERE CREATED, EVOLVED AND DEVELOPED FOR USE ON, AND IN CONNECTION WITH THIS SPECIFIC PROJECT. NONE OF THESE IDEAS, DESIGNS, ARRANGEMENTS OF PLANS SHALL BE USED BY OR DISCLOSED TO ANY PERSON, FIRM, OR CORPORATION FOR ANY PURPOSE WHATSOEVER WITHOUT THE WRITTEN PERMISSION OF WILLIAM PASHELINSKY ARCHITECT

NO.	DATE	DESCRIPTION
1	05.15.19	PLANNING REV
2	01.03.19	PLANNING REV

PROJECT NO. 2017.32
SHEET

A-4.01

**NEW 3 UNIT
 RESIDENCE OVER
 COMMERCIAL SPACE**
 1420 TARAVAL STREET
 SAN FRANCISCO, CA.

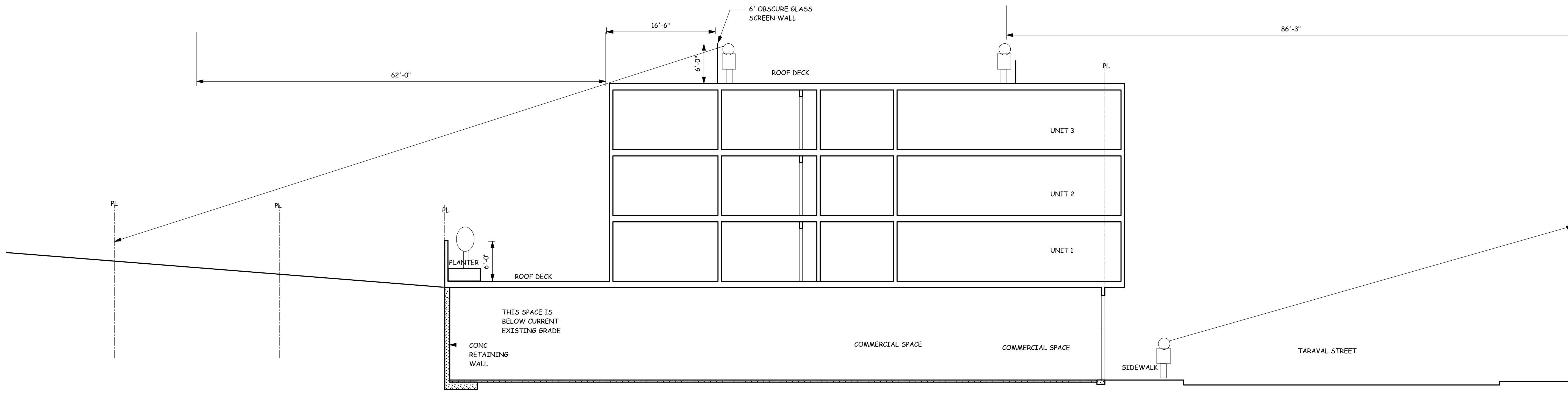

SECTION (N)
 1/8"=1'-0"

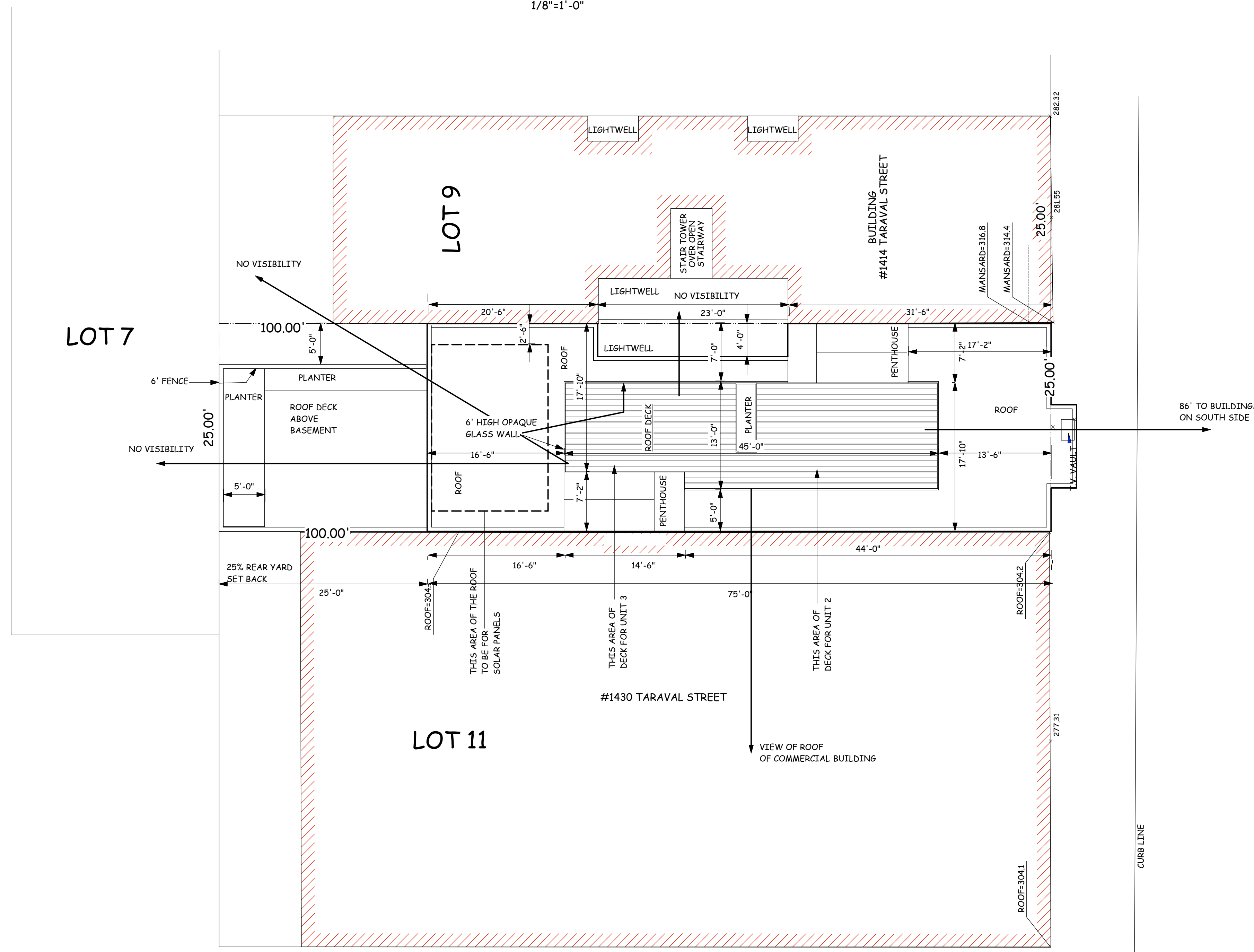

SITE PLAN (N)
 1/8"=1'-0"

ROOF DECK ANALYSIS

ALL IDEAS, DESIGNS, ARRANGEMENTS AND PLANS AS INDICATED OR REPRESENTED BY THIS DRAWING ARE OWNED BY AND ARE THE PROPERTY OF WILLIAM PASHELINSKY ARCHITECT AND WERE CREATED, EVOLVED AND DEVELOPED FOR USE ON, AND IN CONNECTION WITH THIS SPECIFIC PROJECT. NONE OF THESE IDEAS, DESIGNS, ARRANGEMENTS OF PLANS SHALL BE USED BY OR DISCLOSED TO ANY PERSON, FIRM, OR CORPORATION FOR ANY PURPOSE WHATSOEVER WITHOUT THE WRITTEN PERMISSION OF WILLIAM PASHELINSKY ARCHITECT

NO.	DATE	DESCRIPTION
4	01.93.20	PLANNING REV

PROJECT NO. 2017.32
 SHEET



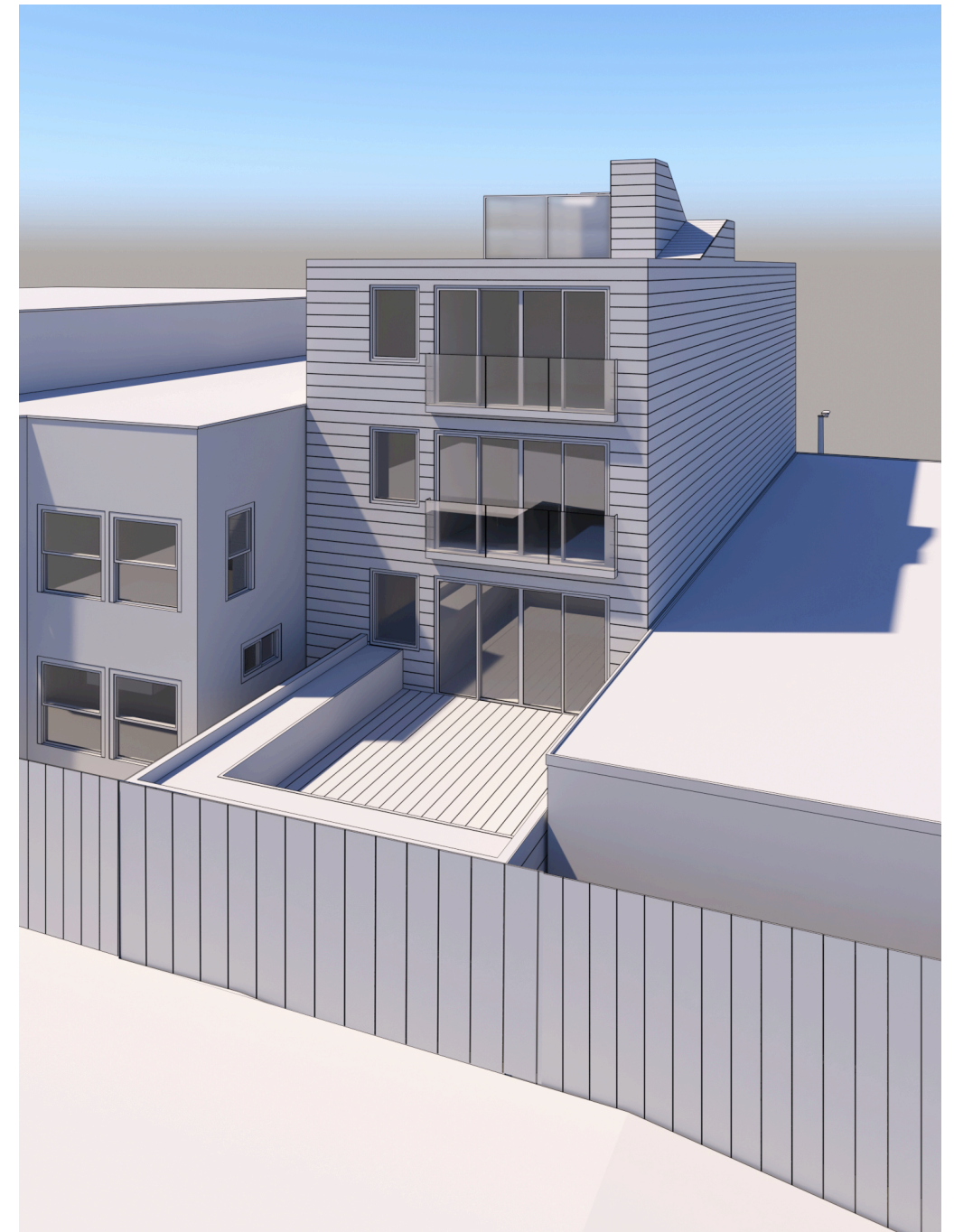
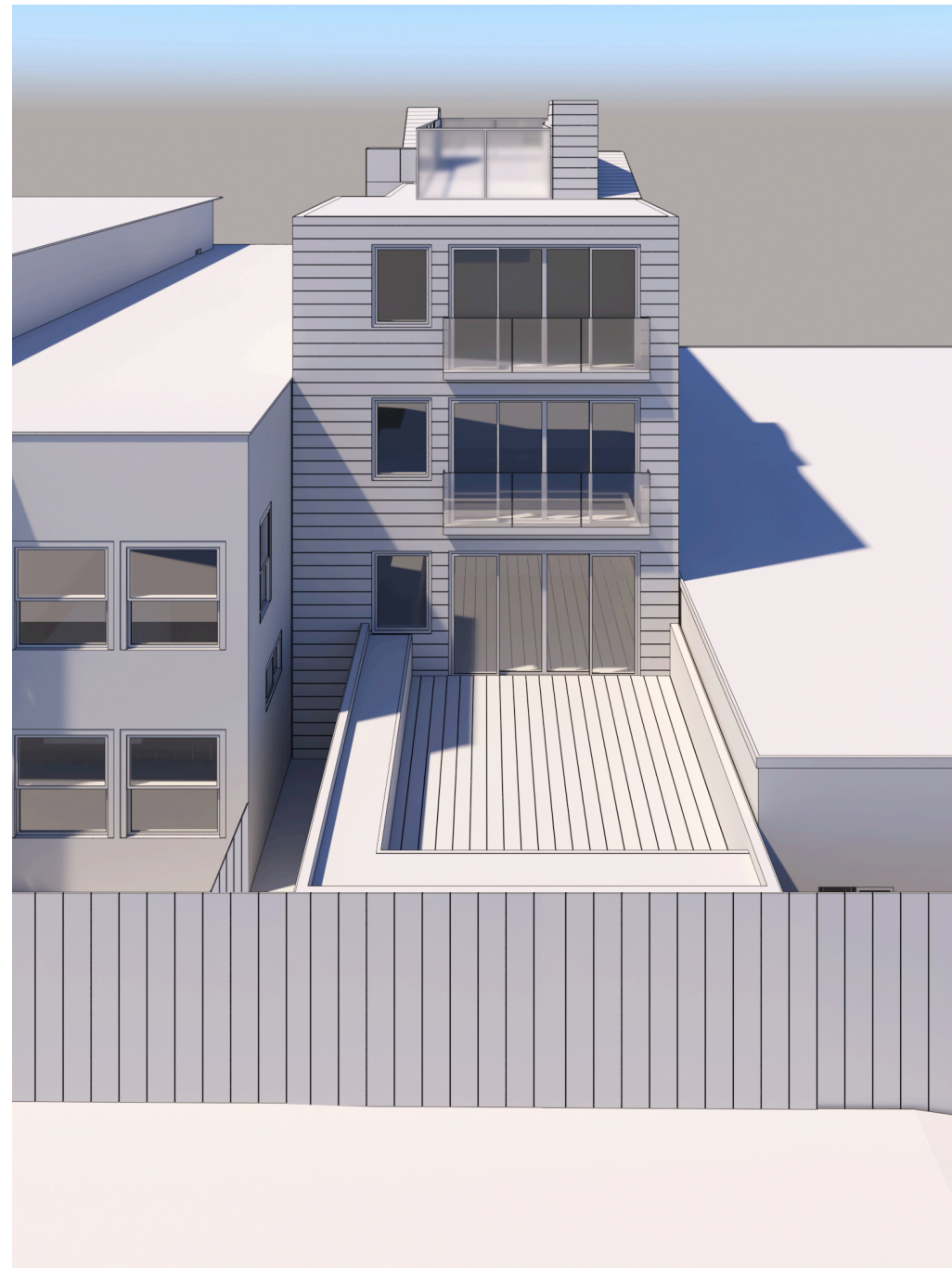
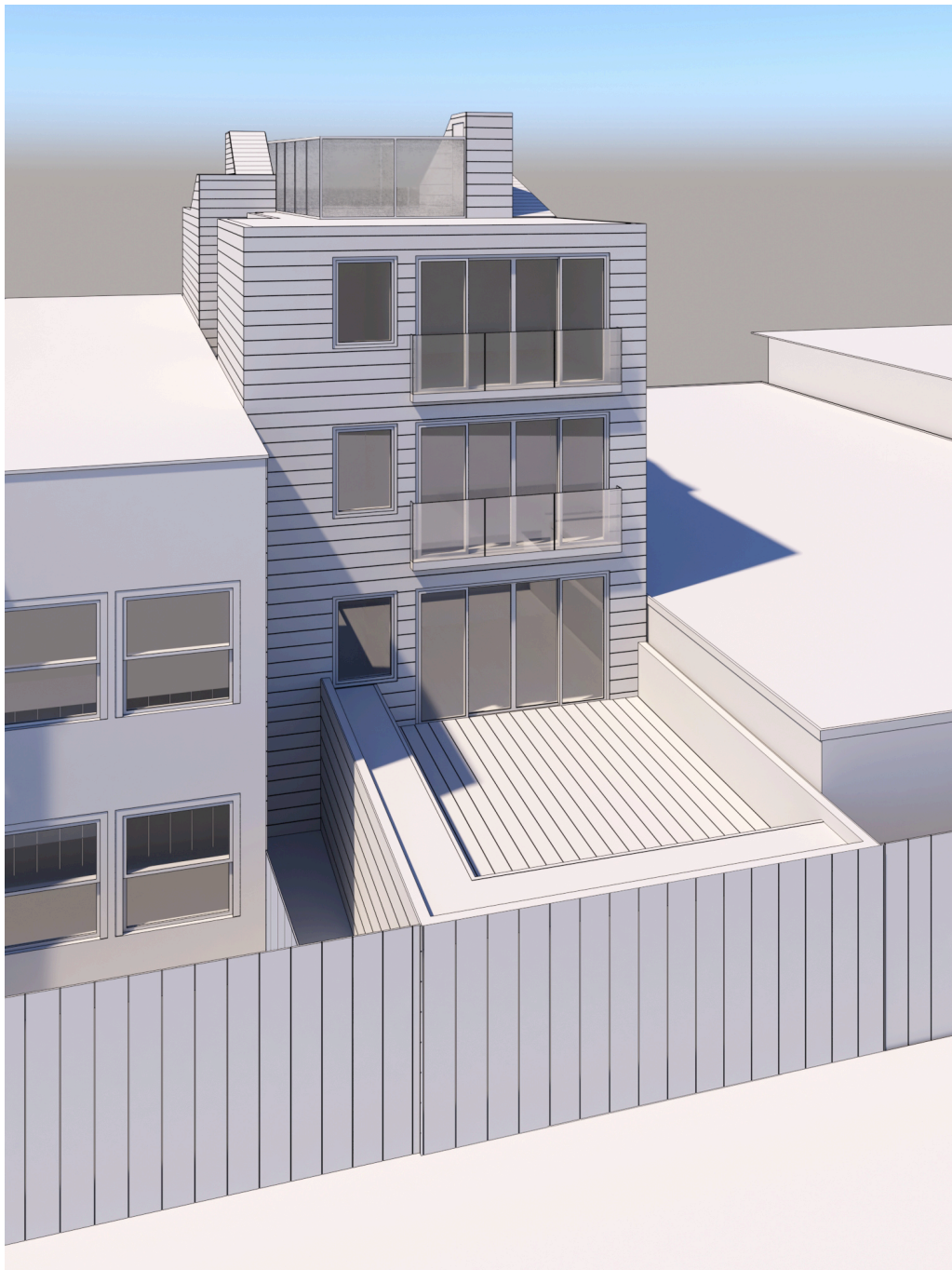

1420 TARAVAL STREEET
REAR VIEW



1420 TARAVAL STREET
REAR VIEW