



SAN FRANCISCO PLANNING DEPARTMENT

Executive Summary Conditional Use – Formula Retail

HEARING DATE: AUGUST 31, 2017
CONSENT CALENDAR

Date: August 24, 2017
Case No.: **2017-004404CUA**
Project Address: **1415 Van Ness Avenue**
Zoning: RC-4 (Residential-Commercial, High Density)
Van Ness Special Use District
Van Ness Automotive Special Use District
130-V Height and Bulk District
Block/Lot: 0666 / 004
Project Sponsor: Robert Jacknewitz
2324 Hampton Avenue
St. Louis, MO 63139
rjacknew@permitconsultants.com or (314) 647-5100
Staff Contact: David Weissglass – (415) 575-9177
david.weissglass@sfgov.org
Recommendation: **Approve with Conditions**

1650 Mission St.
Suite 400
San Francisco,
CA 94103-2479

Reception:
415.558.6378

Fax:
415.558.6409

Planning
Information:
415.558.6377

PROJECT DESCRIPTION

This is a request for **Conditional Use Authorization** pursuant to Planning Code Sections 303 and 303.1 to allow a change of operator of an existing Formula Retail mattress store (d.b.a. "Sleep Train Mattress Center") to another Formula Retail mattress store (d.b.a. "Mattress Firm") in a 6,000 square-foot tenant space at the ground floor of the two-story commercial building within the RC-4 (Residential-Commercial, High Density) Zoning District, the Van Ness Special Use District, the Van Ness Automotive Special Use District, and a 130-V Height and Bulk District. The total floor area of the space will not change with this Project. The project is a change in name only and does not include any tenant improvements beyond a change of the existing signage. Sleep Train Mattress Center and Mattress Firm are both owned by parent company Mattress Firm. Mattress Firm recently acquired Sleep Train and has been converting Sleep Train Mattress Center stores into Mattress Firm stores. The existing staff, product assortment, and interior layout will not be changed as a result of this project.

SITE DESCRIPTION AND PRESENT USE

The Project Site, Lot 004 in Assessor's Block 0666, is located at the corner of Austin Street and Van Ness Avenue in the RC-4 (Residential-Commercial, High Density) Zoning District, the Van Ness Special Use District, and the Van Ness Automotive Special Use District in the Western Addition neighborhood. The property is developed with a 12,000 square-foot commercial building with one retail space on the ground

floor fronting on Van Ness Avenue. The building, constructed circa 1900, occupies nearly the entire 6,000 square-foot lot, with street frontage on Van Ness Avenue and Austin Street. The primary façade faces east onto Van Ness Avenue. The tenant space is currently occupied by the “Sleep Train Mattress Center” proposed for a change in operations.

SURROUNDING PROPERTIES AND NEIGHBORHOOD

The subject RC-4 Zoning District covers approximately 16 blocks of Van Ness Avenue between Broadway in the north and Golden Gate Avenue in the south, as well as portions of Polk Street and several blocks of the Downtown/Civic Center neighborhood. The surrounding development consists of a variety of commercial and mixed-use buildings. The scale of development is varied, consisting primarily of structures three to five stories in height, with several mid-rise buildings scattered throughout. The RC-4 Zoning District is intended to recognize, protect, conserve, and enhance areas characterized by structures combining Residential uses with neighborhood-serving Commercial uses. The surrounding zoning is primarily Neighborhood Commercial, including the Polk Street NCD and NC-3 Districts.

ENVIRONMENTAL REVIEW

The project is not defined as a project under CEQA Guidelines Sections 15060(c)(2) and 15378 because it does not result in a physical change in the environment.

HEARING NOTIFICATION REQUIREMENTS

TYPE	REQUIRED PERIOD	REQUIRED NOTICE DATE	ACTUAL NOTICE DATE	ACTUAL PERIOD
Classified News Ad	20 days	August 11, 2017	August 11, 2017	20 days
Posted Notice	20 days	August 11, 2017	August 7, 2017	24 days
Mailed Notice	30 days	August 1, 2017	August 1, 2017	30 days

The required Section 312 neighborhood notification process was conducted as part of this Project’s Conditional Use notice.

PUBLIC COMMENT/COMMUNITY OUTREACH

- As of August 24, 2017, the Planning Department has not received any public comment in support of or in opposition to the proposed project.
- The project sponsor held a Planning Department Facilitated Pre-Application Meeting on February 28, 2017.

ISSUES AND OTHER CONSIDERATIONS

- The proposed establishment is considered a Formula Retail use with approximately 270 locations throughout California, Nevada, Oregon and Washington. Formula Retail findings are included in the Draft Motion for the Commission to consider.
- The project would rename an existing Formula Retail use within the RC-4 Zoning District and thus result in no net change in the number of Formula Retail uses within the district.

- The project is a change of name only. The location will continue to be owned by parent company The Mattress Firm; the staff, interior layout, and product assortment will not change as part of this project.
- There are approximately 32 existing Formula Retail establishments out of 93 commercial uses within the surveyed portion of the subject RC-4 Zoning District, amounting to a total concentration of approximately 34.41%. The proposal renames an existing Formula Retail use and therefore will have no effect on the concentration of Formula Retail uses.
- Of the 32 Formula Retail locations within the surveyed portion of the RC-4 Zoning District, three are mattress stores.

REQUIRED COMMISSION ACTION

A Conditional Use Authorization is required to allow a change of operator from one Formula Retail Sales and Services use to another Formula Retail Sales and Services use. A Formula Retail use may be conditionally permitted per Planning Code Sections 303 and 303.1.

BASIS FOR RECOMMENDATION

- Mattress Firm will continue the historic use of the subject site as a Formula Retail mattress store.
- The proposed use would not increase the overall concentration of Formula Retail establishments within the RC-4 Zoning District.
- The subject site is within close access to public transit, including Muni lines 1, 2, 3, 19, 47, and 49.
- The project meets all applicable requirements of the Planning Code.
- The project meets the requirements of the Planning Commission's Performance-Based Design Guidelines.
- The project is desirable for and compatible with the surrounding neighborhood.

RECOMMENDATION: Approval with Conditions
--

Attachments:

- Block Book Map
- Sanborn Map
- Zoning Map
- Aerial Photograph
- Site Photograph
- Map of Formula Retail Locations in the Vicinity
- Project Sponsor Submittal

Exhibit Checklist

- | | |
|---|---|
| <input checked="" type="checkbox"/> Executive Summary | <input checked="" type="checkbox"/> Project sponsor submittal |
| <input checked="" type="checkbox"/> Draft Motion | Drawings: <u>Existing Conditions</u> |
| <input type="checkbox"/> Environmental Determination | <input checked="" type="checkbox"/> Check for legibility |
| <input checked="" type="checkbox"/> Zoning District Map | Drawings: <u>Proposed Project</u> |
| <input type="checkbox"/> Height & Bulk Map | <input checked="" type="checkbox"/> Check for legibility |
| <input checked="" type="checkbox"/> Block Book Map | <input type="checkbox"/> Health Dept. review of RF levels |
| <input checked="" type="checkbox"/> Sanborn Map | <input type="checkbox"/> RF Report |
| <input checked="" type="checkbox"/> Aerial Photos | <input type="checkbox"/> Community Meeting Notice |
| <input type="checkbox"/> Context Photo | <input type="checkbox"/> Public Correspondence |
| <input checked="" type="checkbox"/> Site Photo | |

Exhibits above marked with an "X" are included in this packet

DNW

Planner's Initials

Block Book Map

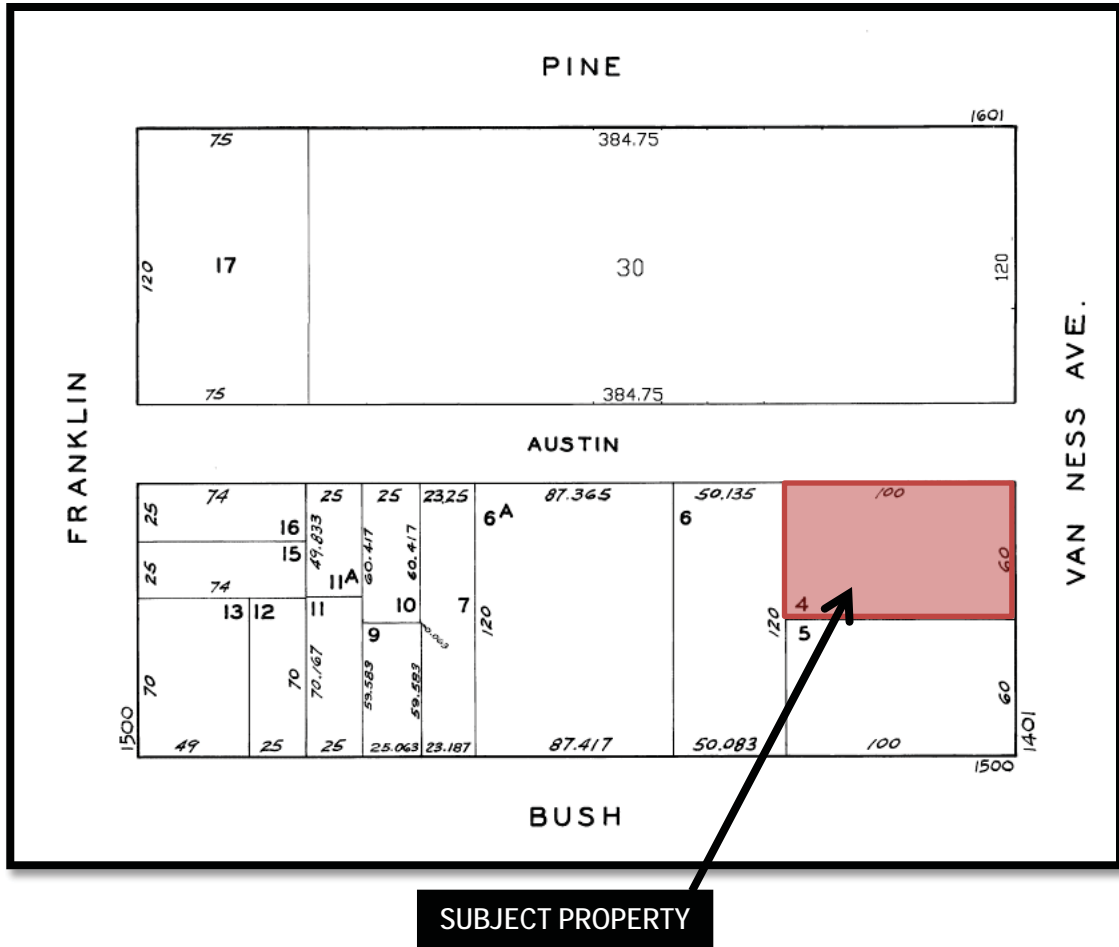

SAN FRANCISCO
PLANNING DEPARTMENT



Conditional Use Hearing
Case Number 2017-004404CUA
1415 Van Ness Avenue
Block 0666 Lot 004

Sanborn Map



SUBJECT PROPERTY



Zoning Map

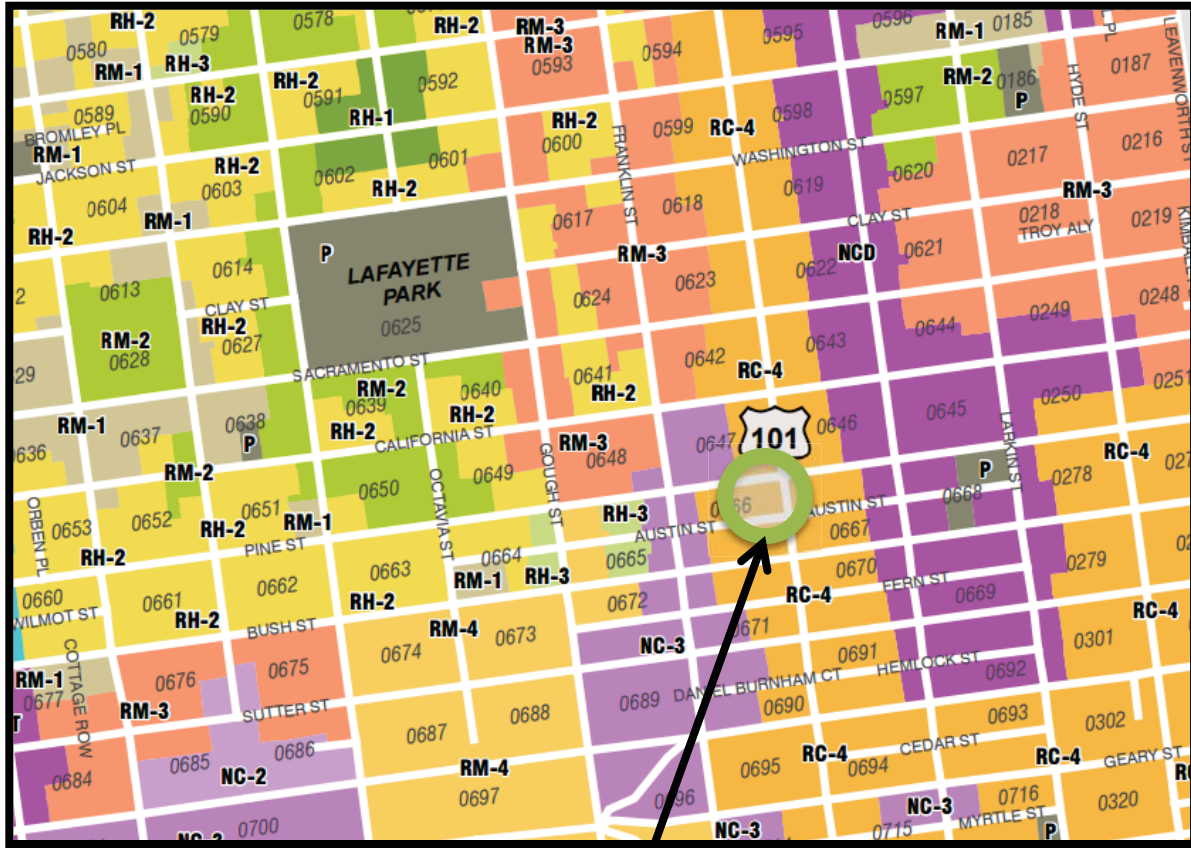

SUBJECT PROPERTY

SAN FRANCISCO
PLANNING DEPARTMENT



Conditional Use Hearing
Case Number 2017-004404CUA
1415 Van Ness Avenue
Block 0666 Lot 004

Aerial Photo

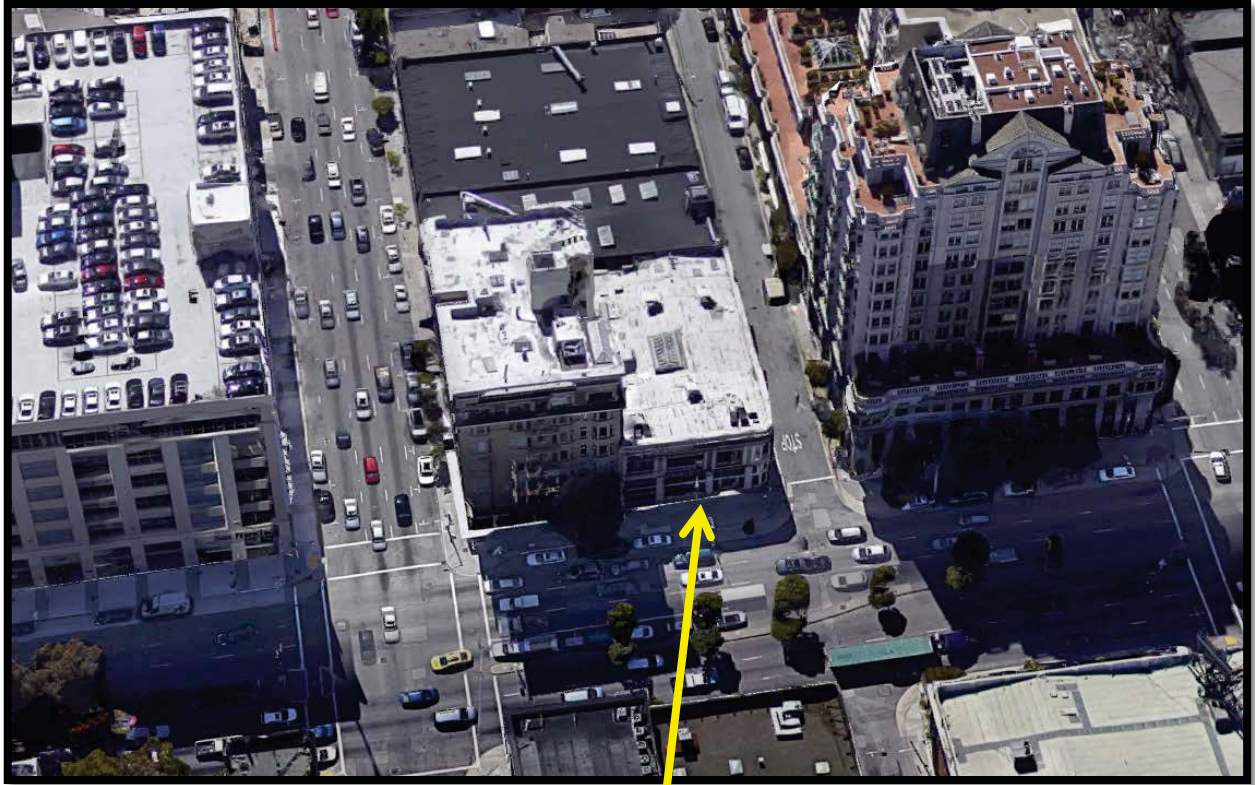

SUBJECT PROPERTY

SAN FRANCISCO
PLANNING DEPARTMENT



Conditional Use Hearing
Case Number 2017-004404CUA
1415 Van Ness Avenue
Block 0666 Lot 004

Site Photo



SAN FRANCISCO
PLANNING DEPARTMENT



Conditional Use Hearing
Case Number 2017-004404CUA
1415 Van Ness Avenue
Block 0666 Lot 004

Formula Retail Locations within RC-4 Survey Area

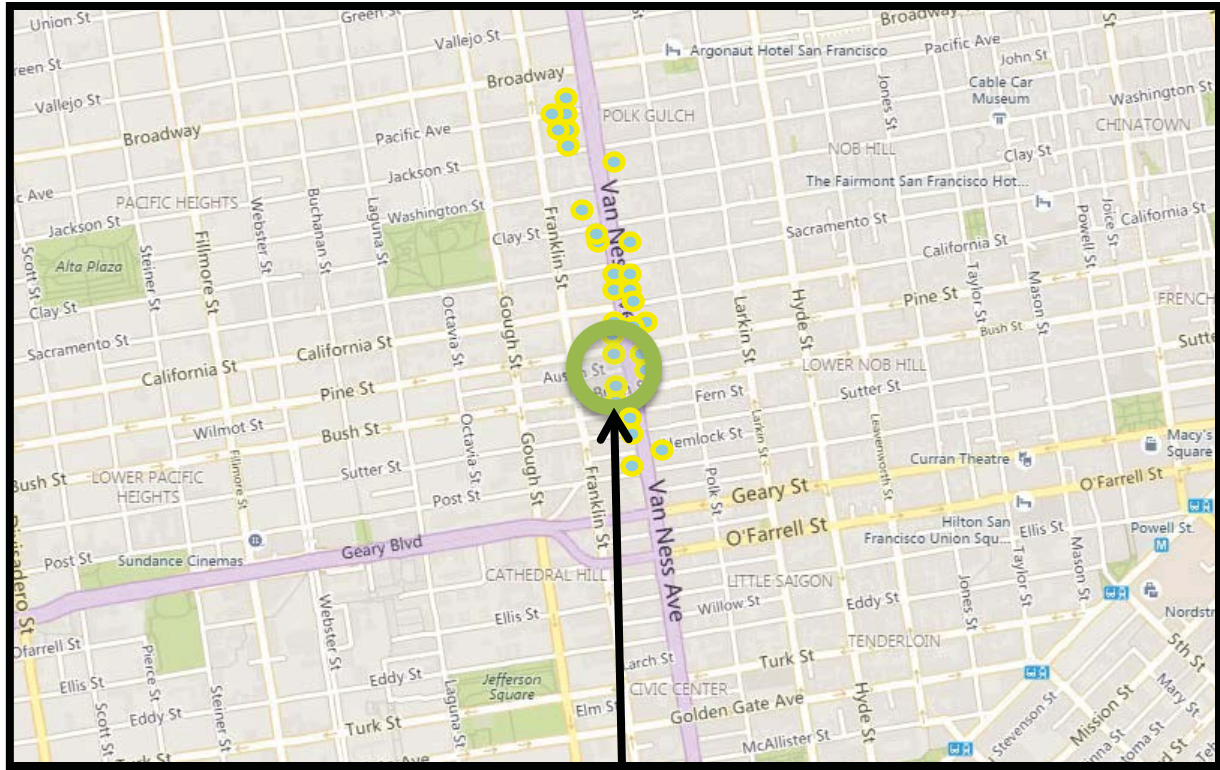

SUBJECT PROPERTY

**SAN FRANCISCO
PLANNING DEPARTMENT**



Conditional Use Hearing
Case Number 2017-004404CUA
1415 Van Ness Avenue
Block 0666 Lot 004



SAN FRANCISCO PLANNING DEPARTMENT

Subject to: (Select only if applicable)

- Affordable Housing (Sec. 415)
- Jobs Housing Linkage Program (Sec. 413)
- Downtown Park Fee (Sec. 412)
- First Source Hiring (Admin. Code)
- Child Care Requirement (Sec. 414)
- Other

1650 Mission St.
Suite 400
San Francisco,
CA 94103-2479

Reception:
415.558.6378

Fax:
415.558.6409

Planning
Information:
415.558.6377

Planning Commission Draft Motion

HEARING DATE: AUGUST 31, 2017

Date: August 24, 2017
Case No.: **2017-004404CUA**
Project Address: **1415 Van Ness Avenue**
Zoning: RC-4 (Residential-Commercial, High Density)
 Van Ness Special Use District
 Van Ness Automotive Special Use District
 130-V Height and Bulk District
Block/Lot: 0666/004
Project Sponsor: Robert Jacknewitz
 2324 Hampton Avenue
 St. Louis, MO 63139
Staff Contact: David Weissglass – (415) 575-9177
 david.weissglass@sfgov.org

ADOPTING FINDINGS RELATING TO THE APPROVAL OF CONDITIONAL USE AUTHORIZATION PURSUANT TO SECTIONS 303 AND 303.1 OF THE PLANNING CODE TO ALLOW A CHANGE OF OPERATOR FOR AN EXISTING FORMULA RETAIL USE, WITHIN THE RC-4 (RESIDENTIAL-COMMERCIAL COMBINED, HIGH DENSITY) ZONING DISTRICT, THE VAN NESS AND VAN NESS AUTOMOTIVE SPECIAL USE DISTRICTS, AND THE 130-V HEIGHT AND BULK DISTRICT.

PREAMBLE

On April 11, 2017, Rob Jacknewitz (hereinafter “Project Sponsor”) filed an application with the Planning Department (hereinafter “Department”) for Conditional Use Authorization under Planning Code Section(s) 303 and 303.1 to allow a change of operator for an existing Formula Retail use, located within the RC-4 (Residential-Commercial Combined, High Density) Zoning District, the Van Ness and Van Ness Automotive Special use Districts, and the 130-V Height and Bulk District.

On August 31, 2017, the San Francisco Planning Commission (hereinafter “Commission”) conducted a duly noticed public hearing at a regularly scheduled meeting on Conditional Use Application No. 2017-004404CUA.

The project is not defined as a project under CEQA Guidelines Sections 15060(c)(2) and 15378 because it does not result in a physical change in the environment.

The Commission has heard and considered the testimony presented to it at the public hearing and has further considered written materials and oral testimony presented on behalf of the applicant, Department staff, and other interested parties.

MOVED, that the Commission hereby authorizes the Conditional Use requested in Application No. 2017-004404CUA, subject to the conditions contained in "EXHIBIT A" of this motion, based on the following findings:

FINDINGS

Having reviewed the materials identified in the preamble above, and having heard all testimony and arguments, this Commission finds, concludes, and determines as follows:

1. The above recitals are accurate and constitute findings of this Commission.
2. **Site Description and Present Use.** The project site is located at the southwest corner of Austin Street and Van Ness Avenue on the eastern edge of the Western Addition neighborhood, Assessor's Block 0666, Lot 004. The parcel is approximately 6,000 square feet in area and is occupied by a two-story commercial building constructed circa 1900. The tenant space on the ground floor is approximately 6,000 square feet in size and is currently occupied by a Formula Retail mattress store (dba "Sleep Train Mattress Center").
3. **Surrounding Neighborhood.** The project site is located on the Van Ness Avenue commercial corridor on the southwest corner of Austin Street and Van Ness Avenue. This portion of Van Ness Avenue is designated as US Highway 101 and is auto-oriented in nature. The subject RC-4 Zoning District covers approximately 16 blocks of Van Ness Avenue between Broadway in the north and Golden Gate Avenue in the south, as well as portions of Polk Street and several blocks of the Downtown/Civic Center neighborhood. The surrounding development consists of a variety of commercial and mixed-use buildings. The scale of development is varied, consisting primarily of structures three to five stories in height, with several mid-rise buildings scattered throughout. The RC-4 Zoning District is intended to recognize, protect, conserve, and enhance areas characterized by structures combining Residential uses with neighborhood-serving Commercial uses. The surrounding zoning is primarily Neighborhood Commercial, including the Polk Street NCD and NC-3 Districts.
4. **Project Description.** The project is a change of name only (from an existing Formula Retail Mattress Store dba "Sleep Train Mattress Center" to another Formula Retail Mattress Store dba "Mattress Firm") in the existing 6,000 square-foot tenant space and does not include any tenant improvements beyond a change of the existing signage. Sleep Train Mattress Center and Mattress Firm are both owned by parent company Mattress firm. Mattress Firm recently acquired Sleep Train and has been converting Sleep Train Mattress Center stores into Mattress Firm stores.

The existing staff, product assortment, and interior layout will not be changed as a result of this project.

5. **Public Comment.** As of August 24, 2017, the Planning Department has not received any public comment in support of or in opposition to the proposed project.

The project sponsor held a Planning Department Facilitated Pre-Application Meeting regarding the proposal on February 28, 2017.

6. **Planning Code Compliance:** The Commission finds that the Project is consistent with the relevant provisions of the Planning Code in the following manner:

- A. **Street Frontage in RC Districts.** Planning Code Section 145.1 requires that within RC Districts space for active uses shall be provided within the first 25 feet of building depth on the ground floor and 15 feet on floors above from any facade facing a street at least 30 feet in width. In addition, the floors of street-fronting interior spaces housing non-residential active uses and lobbies shall be as close as possible to the level of the adjacent sidewalk at the principal entrance to these spaces. Frontages with active uses that must be fenestrated with transparent windows and doorways for no less than 60 percent of the street frontage at the ground level and allow visibility to the inside of the building. The use of dark or mirrored glass shall not count towards the required transparent area. Any decorative railings or grillwork, other than wire mesh, which is placed in front of or behind ground floor windows, shall be at least 75 percent open to perpendicular view. Rolling or sliding security gates shall consist of open grillwork rather than solid material, so as to provide visual interest to pedestrians when the gates are closed, and to permit light to pass through mostly unobstructed. Gates, when both open and folded or rolled as well as the gate mechanism, shall be recessed within, or laid flush with, the building facade.

The first 25' of building depth on the ground floor is devoted to an active retail use. The primary façade of the subject storefront is glazed and the proposed storefront design would respect the existing storefront transparency. No obscured glazing or other elements that would reduce the level of transparency at the ground floor will be used. The project does not propose any decorative railings or grillwork in front of or behind existing windows.

- B. **Off-Street Parking.** Off-street parking is not required for non-residential uses in the RC-4 Zoning District per Planning Code Section 151.1. A maximum of one space per 1,500 square feet of occupied floor area is permitted.

The project does not propose any off-street parking or loading.

- C. **Loading.** Section 152 requires off-street freight loading for uses above a certain size. Retail uses up to 10,000 square feet in gross floor area are not required to provide off-street freight loading.

The project is less than 10,000 square feet in gross floor area and is therefore not required to provide off-street freight loading.

- D. Use Size.** Planning Code Section 209.3 establishes size limits on nonresidential uses in the RC Zoning Districts. Within the District, conditional use authorization is required for any nonresidential use that is 6,000 square feet or larger.

The proposed use will occupy the same 6,000 square feet of space as the prior use and therefore does not require Conditional Use authorization for use size.

- E. Van Ness Automotive Special Use District.** Planning Code Section 237 establishes the Van Ness Automotive Special Use District in order to provide a major automotive area with a citywide and regional market.

The proposed use is not an automotive use and the controls of this Special Use District do not apply.

- F. Van Ness Special Use District.** Planning Code Section 243 establishes the Van Ness Special Use District in order to implement the objectives and policies of the Van Ness Avenue Area Plan.

The controls specified in Planning Code Section 243(c) are not applicable due to the limited scope of the proposal. The proposal does not include any new construction, changes of use, or alterations to an existing structure.

- 7. Conditional Use Authorization.** Planning Code Section 303(c) establishes criteria for the Planning Commission to consider when reviewing applications for Conditional Use approval. On balance, the project does comply with said criteria in that:

- a. The proposed new uses and building, at the size and intensity contemplated and at the proposed location, will provide a development that is necessary or desirable, and compatible with, the neighborhood or the community.

The proposed project is desirable because it will continue the existing commercial use which is compatible with the surrounding commercial nature of the Van Ness Avenue corridor.

- b. The proposed project will not be detrimental to the health, safety, convenience or general welfare of persons residing or working in the vicinity. There are no features of the project that could be detrimental to the health, safety or convenience of those residing or working the area, in that:

- i. Nature of proposed site, including its size and shape, and the proposed size, shape and arrangement of structures;

The size and shape of the site and the size, shape and arrangement of the building will not be altered as part of this project. The project will not affect the building envelope.

- ii. The accessibility and traffic patterns for persons and vehicles, the type and volume of such traffic, and the adequacy of proposed off-street parking and loading;

The project will not affect public transit or overburden the existing supply of parking in the neighborhood. The project may attract residents and visitors from outside of the neighborhood; however, this area is well serviced by transit, including Muni lines 1, 2, 3, 19, 47 and 49.

- iii. The safeguards afforded to prevent noxious or offensive emissions such as noise, glare, dust and odor;

The project will not produce noxious or offensive emissions related to noise, glare and dust.

- iv. Treatment given, as appropriate, to such aspects as landscaping, screening, open spaces, parking and loading areas, service areas, lighting and signs;

The project would not alter the site's landscaping, open spaces, parking and loading areas, service areas, and lighting. Any new signage must comply with the requirements of the Planning Code.

- c. That the use as proposed will comply with the applicable provisions of the Planning Code and will not adversely affect the General Plan.

The project complies with all relevant requirements and standards of the Planning Code and is consistent with objectives and policies of the General Plan as detailed below.

- d. That the use as proposed would provide development that is in conformity with the purpose of the applicable Zoning District.

The proposed project is consistent with the stated purpose of the RC-4 Zoning District in that the intended use will provide a compatible retail use and is compliant with the limitations on certain uses within the district.

- 8. **Formula Retail.** Planning Code Section 703.3 provides additional criteria for the Planning Commission to consider when considering any discretionary review pursuant to Section 703.3, Formula Retail Uses:

- a. The existing concentrations of Formula Retail uses within the district.

Due to the large and irregular size of the subject RC-4 Zoning District, the survey area was reduced to include only those parcels along the Van Ness Avenue corridor between Broadway and Golden Gate Avenue, west of Polk Street. This study area is hereinafter referred to as "the district."

There are approximately 32 existing ground story Formula Retail establishments out of approximately 93 commercial establishments within the district. The existing intensity of

Formula Retail uses is approximately 34.41% of all businesses within the district, and 48.51% of the total commercial retail street frontage. The proposed establishment renames an existing Formula Retail use, resulting in no net change in concentration.

Based on an evaluation of the linear frontage of all retail locations located within a ¼ mile of the subject property, 40 of 278 commercial establishments are Formula Retail. This comprises approximately 14.39% of the businesses and 34.29% of the commercial street frontage at the ground floor. The proposed establishment renames an existing Formula Retail use, resulting in no net change in concentration.

- b. The availability of other similar retail uses within the district.

Within the district there are three mattress retailers, including the subject Sleep Train store as well as the Sleep Train store located at 1600 Van Ness Avenue also proposed for a name and operator change. All three retailers are considered Formula Retail uses. Approval of this project would not affect the availability of similar retail uses within the district.

- c. The compatibility of the proposed Formula Retail use with the existing architectural and aesthetic character of the district.

The project will occupy an existing location currently occupied by a Formula Retail use (dba "Sleep Train Mattress Center") and no exterior alterations are proposed besides signage alterations. Therefore, the proposed use will have no effect on the architectural and aesthetic character of the district. Preliminary signage plans submitted to the Department for review did not meet the Planning Department's Formula Retail sign guidelines. Therefore, the sign permit submitted for approval will have to be further reviewed. The signs will be required to have a permit and comply with the requirements of the Planning Code and the Formula Retail sign guidelines. Storefront Transparency guidelines are met: greater than 60% of ground floor street frontage allows visibility into the building with transparent glass.

- d. The existing retail vacancy rates within the district.

According to data provided by the project sponsor, there are currently 16 vacant storefronts within the district (17.20% vacancy rate) and 31 vacant storefronts within ¼-mile of the subject property (11.15% vacancy rate). Approximately 1,046 of 6,953 linear feet, or 15.04% of the total street frontage, is vacant within the district, and 1,466, or 11.36% of the total street frontage, is vacant within ¼-mile of the subject property.

- e. The existing mix of Citywide-serving retail uses and neighborhood-serving retail uses within the district.

Approximately 18.28% (17 locations) of the ground floor commercial uses in the district are "Daily-Needs," or neighborhood-serving; of these, nine are Formula Retail. Approximately 64.52% (60 locations) of ground floor commercial uses in the district are considered "Citywide-serving." The existing and proposed uses are both considered Citywide-serving.

- f. Additional data and analysis set forth in the Performance-Based Design Guidelines adopted by the Planning Commission.

Table 1. RC-4 Ground Floor Frontage Breakdown per Land Use¹

LAND USE TYPE	TOTAL STREET FRONTAGE IN RC-4 SURVEY AREA (FT)	PERCENTAGE OF DISTRICT
Automotive	1667	24.0%
Bar	45	0.6%
Entertainment	120	1.7%
Financial Services (incl. Limited)	258	3.7%
Hotel	500	7.2%
Institutional	80	1.2%
Medical Service	50	0.7%
Personal Service	122	1.8%
Professional Service	145	2.1%
Restaurant (incl. Limited)	1207	17.4%
Other Retail	1713	24.6%
Vacant	1046	15.0%
Total	6953	100%

The use mix is varied in the district. Other Retail uses, including the proposed use, comprise approximately 24.6% of the commercial frontage.

- g. For Formula Retail uses of 20,000 square feet or more, except for General or Specialty Grocery stores as defined in Articles 2, 7, 8 of this Code, the contents of an economic impact study prepared pursuant to Section 303(i) of the Planning Code.

As the subject retail use is less than 20,000 square feet, an economic impact study is not required for this project.

9. **General Plan Compliance.** The project is, on balance, consistent with the Objectives and Policies of the General Plan.

LAND USE

Objectives and Policies

¹ The RC-4 Ground Floor Frontage Breakdown per Land Use table was developed using data collected by the project sponsor and reviewed by Planning Department Staff in 2017. This data reflects only those portions of the subject RC-4 Zoning District on either side of Van Ness Avenue, west of Polk Street.

OBJECTIVE 1:

CONTINUE EXISTING COMMERCIAL USE OF THE AVENUE AND ADD A SIGNIFICANT INCREMENT OF NEW HOUSING.

Policy 1.2:

Allow existing structures to remain in non-residential use.

The project continues the historic retail use of the existing structure.

STREETSCAPE

Objectives and Policies

OBJECTIVE 8:

CREATE AN ATTRACTIVE STREET AND SIDEWALK SPACE WHICH CONTRIBUTES TO THE TRANSFORMATION OF VAN NESS AVENUE INTO A RESIDENTIAL BOULEVARD.

Policy 8.11:

Permit general advertising signs, business signs and other identifying signs. Permitted signs should meet the design criteria specified in the Van Ness Avenue Area Plan.

The proposed signage meets the design criteria specified in the Van Ness Avenue Area Plan and shall be made to comply with the requirements of Article 6 of the Planning Code.

CONSERVATION

Objectives and Policies

OBJECTIVE 11:

PRESERVE THE FINE ARCHITECTURAL RESOURCES OF VAN NESS AVENUE.

Policy 1.1:

Avoid demolition or inappropriate alteration of historically and architecturally significant buildings.

The subject building at 1415 Van Ness Avenue is identified in Appendix A of the Van Ness Avenue Area Plan as a significant building. The project does not propose any alterations to the building, with the exception of new signage, thereby protecting this significant building from demolition or inappropriate alterations.

10. **General Plan Compliance.** The project is consistent with the Objectives and Policies of the General Plan:

COMMERCE AND INDUSTRY

Objectives and Policies

OBJECTIVE 1:

MANAGE ECONOMIC GROWTH AND CHANGE TO ENSURE ENHANCEMENT OF THE TOTAL CITY LIVING AND WORKING ENVIRONMENT.

Policy 1.1:

Encourage development which provides substantial net benefits and minimizes undesirable consequences. Discourage development that has substantial undesirable consequences that cannot be mitigated.

Policy 1.2:

Assure that all commercial and industrial uses meet minimum, reasonable performance standards.

Policy 1.3:

Locate commercial and industrial activities according to a generalized commercial and industrial land use plan.

The proposed project will continue to provide desirable goods and services to the neighborhood and will provide resident employment opportunities to those in the community. The conditions of approval will ensure that the use meets minimum, reasonable performance standards. Further, the project site is located within a RC Zoning District and is thus consistent with activities in the commercial land use plan.

OBJECTIVE 2:

MAINTAIN AND ENHANCE A SOUND AND DIVERSE ECONOMIC BASE AND FISCAL STRUCTURE FOR THE CITY.

Policy 2.1:

Seek to retain existing commercial and industrial activity and to attract new such activity to the City.

The project will retain the existing commercial use and will not result in a change of ownership of the subject business.

11. **Planning Code Section 101.1(b)** establishes eight priority-planning policies and requires review of permits for consistency with said policies. On balance, the project does comply with said policies in that:

- A. That existing neighborhood-serving retail uses be preserved and enhanced and future opportunities for resident employment in and ownership of such businesses be enhanced.

The proposal would retain the existing mix of neighborhood-serving retail uses.

- B. That existing housing and neighborhood character be conserved and protected in order to preserve the cultural and economic diversity of our neighborhoods.

The project would not affect the character or diversity of the neighborhood.

- C. That the City's supply of affordable housing be preserved and enhanced,

The project would not have any effect on the City's supply of affordable housing.

- D. That commuter traffic not impede MUNI transit service or overburden our streets or neighborhood parking.

The project would not adversely affect public transit or place a burden on the existing supply of parking in the neighborhood. The Project Site is well-served by public transit, including Muni lines 1, 2, 3, 19, 47 and 49.

- E. That a diverse economic base be maintained by protecting our industrial and service sectors from displacement due to commercial office development, and that future opportunities for resident employment and ownership in these sectors be enhanced.

The project will not displace any service or industry establishment. The project will not affect industrial or service sector uses or related employment opportunities. Ownership of industrial or service sector businesses will not be affected by this project.

- F. That the City achieve the greatest possible preparedness to protect against injury and loss of life in an earthquake.

This proposal will not affect the property's ability to withstand an earthquake.

- G. That landmarks and historic buildings be preserved.

The existing building is not a landmark. Exterior improvements are not proposed other than new signage.

- H. That our parks and open space and their access to sunlight and vistas be protected from development.

The project will have no negative effect on existing parks and open spaces. The project does not have an effect on open spaces.

12. The project is consistent with and would promote the general and specific purposes of the Code provided under Section 101.1(b) in that, as designed, the project would contribute to the character and stability of the neighborhood and would constitute a beneficial development.

13. The Commission hereby finds that approval of the Conditional Use Authorization would promote the health, safety and welfare of the City.

DECISION

That based upon the Record, the submissions by the Applicant, the staff of the Department and other interested parties, the oral testimony presented to this Commission at the public hearings, and all other written materials submitted by all parties, the Commission hereby **APPROVES Conditional Use Application No. 2017-004404CUA** subject to the following conditions attached hereto as "EXHIBIT A" in general conformance with plans on file, dated January 6, 2017, and stamped "EXHIBIT B", which is incorporated herein by reference as though fully set forth.

APPEAL AND EFFECTIVE DATE OF MOTION: Any aggrieved person may appeal this Conditional Use Authorization to the Board of Supervisors within thirty (30) days after the date of this Motion No. xxxxx. The effective date of this Motion shall be the date of this Motion if not appealed (After the 30-day period has expired) OR the date of the decision of the Board of Supervisors if appealed to the Board of Supervisors. For further information, please contact the Board of Supervisors at (415) 554-5184, City Hall, Room 244, 1 Dr. Carlton B. Goodlett Place, San Francisco, CA 94102.

Protest of Fee or Exaction: You may protest any fee or exaction subject to Government Code Section 66000 that is imposed as a condition of approval by following the procedures set forth in Government Code Section 66020. The protest must satisfy the requirements of Government Code Section 66020(a) and must be filed within 90 days of the date of the first approval or conditional approval of the development referencing the challenged fee or exaction. For purposes of Government Code Section 66020, the date of imposition of the fee shall be the date of the earliest discretionary approval by the City of the subject development.

If the City has not previously given Notice of an earlier discretionary approval of the project, the Planning Commission's adoption of this Motion, Resolution, Discretionary Review Action or the Zoning Administrator's Variance Decision Letter constitutes the approval or conditional approval of the development and the City hereby gives **NOTICE** that the 90-day protest period under Government Code Section 66020 has begun. If the City has already given Notice that the 90-day approval period has begun for the subject development, then this document does not re-commence the 90-day approval period.

I hereby certify that the Planning Commission ADOPTED the foregoing Motion on August 31, 2017.

Jonas Ionin
Commission Secretary

AYES:

NAYS:

ABSENT:

ADOPTED: August 31, 2017

EXHIBIT A

AUTHORIZATION

This authorization is for a conditional use to allow a change of operator for a Formula Retail use (previously dba "Sleep Train Mattress Center," proposed as "Mattress Firm") located at 1415 Van Ness Avenue , Block 0666, Lot 004 pursuant to Planning Code Sections 303, and 303.1 within the **RC-4 (Residential-Commercial Combined, High Density) Zoning District**, and a **130-V Height and Bulk District**; in general conformance with plans, dated January 6, 2017, and stamped "EXHIBIT B" included in the docket for Case No. **2017-004404CUA** and subject to conditions of approval reviewed and approved by the Commission on **August 31, 2017** under Motion No. **xxxxx**. This authorization and the conditions contained herein run with the property and not with a particular Project Sponsor, business, or operator.

RECORDATION OF CONDITIONS OF APPROVAL

Prior to the issuance of the building permit or commencement of use for the Project the Zoning Administrator shall approve and order the recordation of a Notice in the Official Records of the Recorder of the City and County of San Francisco for the subject property. This Notice shall state that the project is subject to the conditions of approval contained herein and reviewed and approved by the Planning Commission on **August 31, 2017** under Motion No. **xxxxx**.

PRINTING OF CONDITIONS OF APPROVAL ON PLANS

The conditions of approval under the 'Exhibit A' of this Planning Commission Motion No. **xxxxx** shall be reproduced on the Index Sheet of construction plans submitted with the Site or Building permit application for the Project. The Index Sheet of the construction plans shall reference to the Conditional Use authorization and any subsequent amendments or modifications.

SEVERABILITY

The Project shall comply with all applicable City codes and requirements. If any clause, sentence, section or any part of these conditions of approval is for any reason held to be invalid, such invalidity shall not affect or impair other remaining clauses, sentences, or sections of these conditions. This decision conveys no right to construct, or to receive a building permit. "Project Sponsor" shall include any subsequent responsible party.

CHANGES AND MODIFICATIONS

Changes to the approved plans may be approved administratively by the Zoning Administrator. Significant changes and modifications of conditions shall require Planning Commission approval of a new Conditional Use authorization.

Conditions of Approval, Compliance, Monitoring, and Reporting

PERFORMANCE

1. **Validity and Expiration.** The authorization and right vested by virtue of this action is valid for three years from the effective date of the Motion. A building permit from the Department of Building Inspection to construct the project and/or commence the approved use must be issued as this Conditional Use authorization is only an approval of the proposed project and conveys no independent right to construct the project or to commence the approved use. The Planning Commission may, in a public hearing, consider the revocation of the approvals granted if a site or building permit has not been obtained within three (3) years of the date of the Motion approving the Project. Once a site or building permit has been issued, construction must commence within the timeframe required by the Department of Building Inspection and be continued diligently to completion. The Commission may also consider revoking the approvals if a permit for the Project has been issued but is allowed to expire and more than three (3) years have passed since the Motion was approved.

For information about compliance, contact Code Enforcement, Planning Department at 415-575-6863, www.sf-planning.org

2. **Extension.** This authorization may be extended at the discretion of the Zoning Administrator only where failure to issue a permit by the Department of Building Inspection to perform said tenant improvements is caused by a delay by a local, State or Federal agency or by any appeal of the issuance of such permit(s).

For information about compliance, contact Code Enforcement, Planning Department at 415-575-6863, www.sf-planning.org.

DESIGN

3. **Signage.** Any signs on the property shall be made to comply with the requirements of Article 6 of the Planning Code.

For information about compliance, contact Code Enforcement, Planning Department at 415-575-6863, www.sf-planning.org

MONITORING

4. **Enforcement.** Violation of any of the Planning Department conditions of approval contained in this Motion or of any other provisions of Planning Code applicable to this Project shall be subject to the enforcement procedures and administrative penalties set forth under Planning Code Section 176 or Section 176.1. The Planning Department may also refer the violation complaints to other city departments and agencies for appropriate enforcement action under their jurisdiction.

For information about compliance, contact Code Enforcement, Planning Department at 415-575-6863, www.sf-planning.org

OPERATION

5. **Sidewalk Maintenance.** The Project Sponsor shall maintain the main entrance to the tenant space and all sidewalks abutting the subject property in a clean and sanitary condition in compliance with the Department of Public Works Streets and Sidewalk Maintenance Standards.

For information about compliance, contact Bureau of Street Use and Mapping, Department of Public Works, 415-695-2017, <http://sfdpw.org/>

For information about compliance, contact Code Enforcement, Planning Department at 415-575-6863, www.sf-planning.org

MONITORING - AFTER ENTITLEMENT

6. **Enforcement.** Violation of any of the Planning Department conditions of approval contained in this Motion or of any other provisions of Planning Code applicable to this Project shall be subject to the enforcement procedures and administrative penalties set forth under Planning Code Section 176 or Section 176.1. The Planning Department may also refer the violation complaints to other city departments and agencies for appropriate enforcement action under their jurisdiction.

For information about compliance, contact Code Enforcement, Planning Department at 415-575-6863, www.sf-planning.org

7. **Revocation due to Violation of Conditions.** Should implementation of this Project result in complaints from interested property owners, residents, or commercial lessees which are not resolved by the Project Sponsor and found to be in violation of the Planning Code and/or the specific conditions of approval for the Project as set forth in Exhibit A of this Motion, the Zoning Administrator shall refer such complaints to the Commission, after which it may hold a public hearing on the matter to consider revocation of this authorization.

For information about compliance, contact Code Enforcement, Planning Department at 415-575-6863, www.sf-planning.org

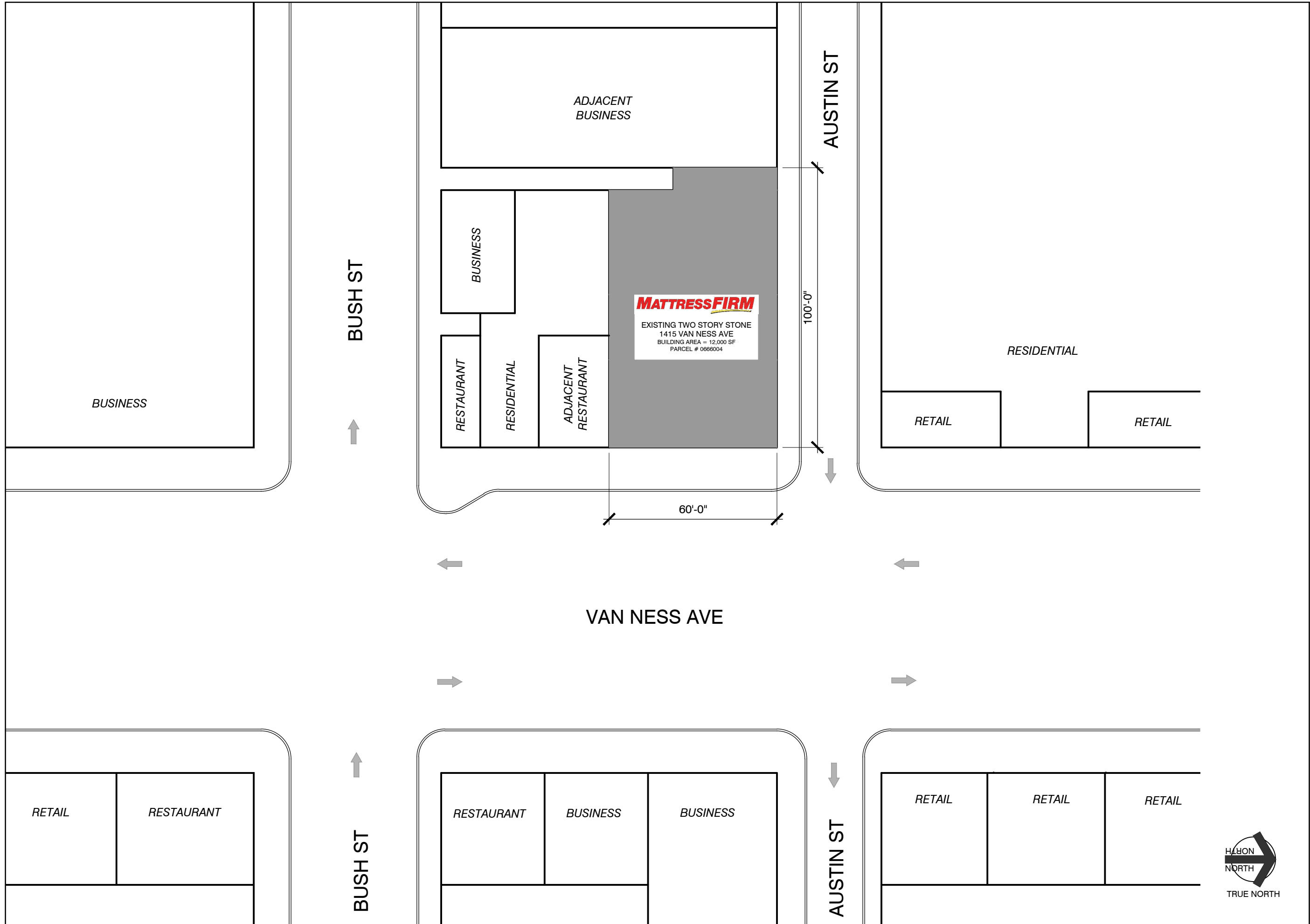

idGROUP
2641 IRVING BLVD.
DALLAS, TEXAS 75207
TEL: 214-638-6800

DESIGN CONSULTANT'S PROJECT NO.: **343-615**
DRAWN BY: KK
CHECKED BY: HW

MATTRESS FIRM

1415 VAN NESS AVENUE
SAN FRANCISCO, CA 94109

PROJECT DESCRIPTION
DRAWING ISSUE 01/06/2017
REVISIONS
▲
▲
▲
DRAWING TITLE PLOT PLAN ATTACHMENT

Van Ness

Job # 13407
1415 Van Ness Ave.
San Francisco, Ca.

MATTRESS FIRM



City Criteria:

RC-4 Residential Commercial High Density

Wall Signs:

(1) Sign per street frontage.
3 sqft per lineal foot of street frontage or
100 sqft, whichever is less.

Free Standing Signs:

If building is recessed from property line, you may be
allowed (1) freestanding in leu of projecting sign.

Canopies:

Sign copy not to exceed 30 sqft instead of projecting signs.

Window Signs:

Not to exceed 1/3 of the window area.

Projecting Signs:

(1) Per business, Not to exceed 36 sqft

Landlord Criteria:

Wall Signs:

Per Code

Free Standing Signs:

Per Code

Canopies:

N/A

Window Signs:

Per Code

X

LANDLORD APPROVAL (SIGNAGE)

**FRONT ELEVATION (EAST)
PAN CHANNEL LETTERS - INTERNAL ILLUMINATION**

QTY: 1

**30.30 SQ.FT PROPOSED
SQ.FT ALLOWED: 100**

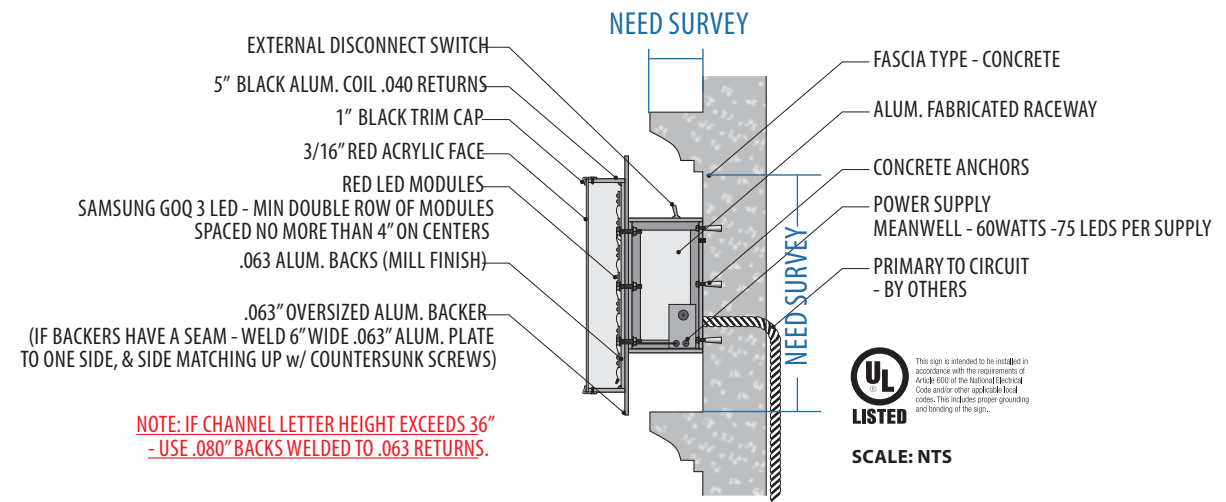
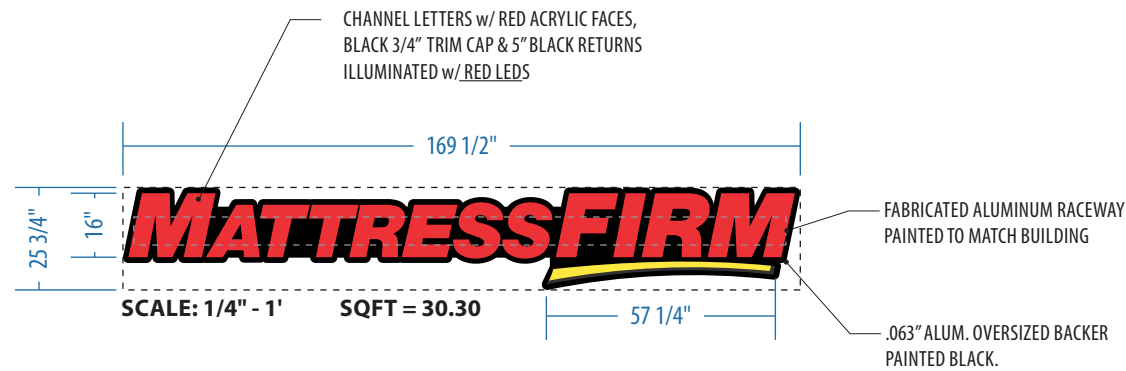

NOTE: IF CHANNEL LETTER HEIGHT EXCEEDS 36" - USE .080" BACKS WELDED TO .063 RETURNS.

LTR SIZE	ALUM. LTR BACKS	RETURNS	ALUM. OVERSIZED BACKER
↓ 24	.050	.040	.063
24 - 36	.063	.040	.063
↑ 36	.080	.063	1/8"

NOTE: SITE SURVEY NEEDED TO DETERMINE EXACT SIZE FOR RACEWAY. TO EXTEND PAST ARCHITECTURAL ELEMENTS & STAY WITHIN BAND ON FASCIA.



AINOR SIGNS
CL# 913842

5443 Stationers Way, Sacramento, CA 95842
916.348.4370 | fax: 916.348.34375

www.ainorsigns.com

EST#: 00000 JOB#: 13407

PROJECT: Mattress Firm
ADDRESS: 1415 Van Ness Ave
CITY, ST: San Francisco CA
ACCT. REP: Joe Bergh
DESIGNER: Brian Elie

DATE: 09.19.16
REVISIONS: A: 10.24.16 B: 10.27.16
C: 01.30.17 D: 08.02.17 E: 08.09.17
F: 00.00.00 G: 00.00.00 H: 00.00.00

EXISTING



PROPOSED



APPROVALS

This is an original unpublished drawing created by Ainoor Signs, Inc. It is submitted for your approval. It is not to be shown to anyone outside your organization, nor is it to be reproduced, copied or exhibited in any fashion. The changing of colors, sizes, materials or illumination method does not alter the design. Ownership of this design is held by Ainoor Signs, Inc. Authorization to use this design in any fashion must be obtained in writing from Ainoor Signs, Inc. Any unauthorized reproduction is subject to a \$1000 design fee.

TENANT:

LANDLORD:

AE / PM:

Note: The colors depicted in this design are a graphic representation. Actual colors may vary due to monitors / printers. See color specifications

**RIGHT SIDE ELEVATION (NORTH)
PAN CHANNEL LETTERS - INTERNAL ILLUMINATION**

QTY: 1

**30.30 SQ.FT PROPOSED
SQ.FT ALLOWED: 100**

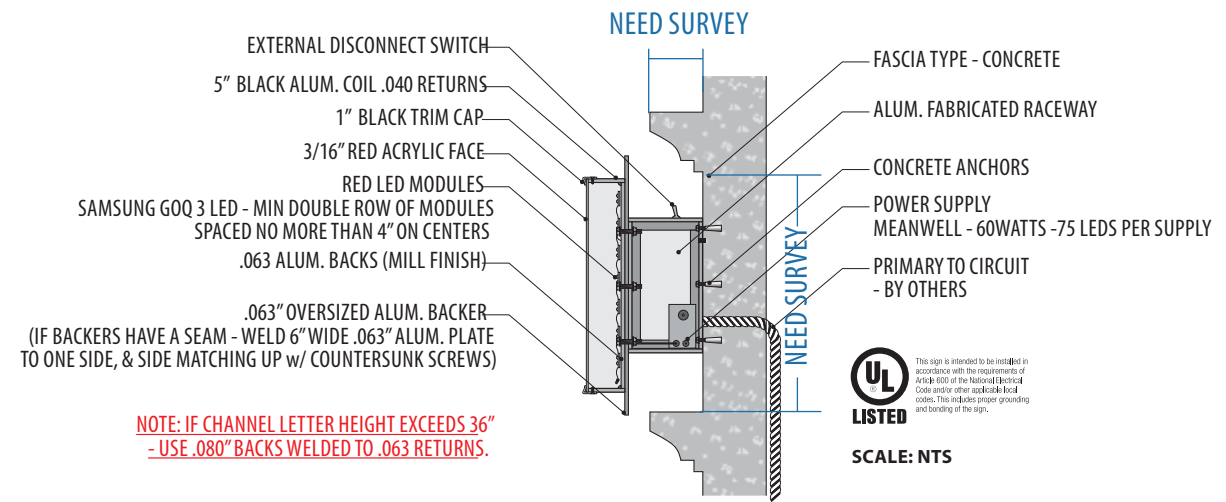
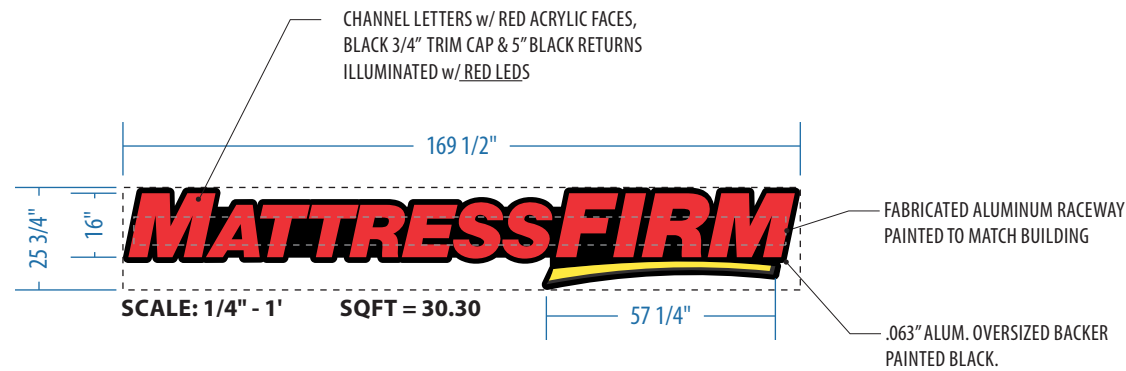

**NOTE: IF CHANNEL LETTER HEIGHT EXCEEDS 36"
- USE .080" BACKS WELDED TO .063 RETURNS.**

LTR SIZE	ALUM. LTR BACKS	RETURNS	ALUM. OVERSIZED BACKER
↓ 24	.050	.040	.063
24 - 36	.063	.040	.063
↑ 36	.080	.063	1/8"

NOTE: SITE SURVEY NEEDED TO DETERMINE EXACT SIZE FOR RACEWAY. TO EXTEND PAST ARCHITECTURAL ELEMENTS & STAY WITHIN BAND ON FASCIA.

AINOR SIGNS
CL# 913842

5443 Stationers Way, Sacramento, CA 95842
916.348.4370 | fax: 916.348.34375

www.ainorsigns.com

EST#: 00000 JOB#: 13407

PROJECT: Mattress Firm
ADDRESS: 1415 Van Ness Ave
CITY, ST: San Francisco CA
ACCT. REP: Joe Bergh
DESIGNER: Brian Elie

DATE: 09.19.16
REVISIONS: A: 10.24.16 B: 10.27.16
C: 01.30.17 D: 08.02.17 E: 08.09.17
F: 00.00.00 G: 00.00.00 H: 00.00.00

APPROVALS

This is an original unpublished drawing created by Ainoor Signs, Inc. It is submitted for your approval. It is not to be shown to anyone outside your organization, nor is it to be reproduced, copied or exhibited in any fashion. The changing of colors, sizes, materials or illumination method does not alter the design. Ownership of this design is held by Ainoor Signs, Inc. Authorization to use this design in any fashion must be obtained in writing from Ainoor Signs, Inc. Any unauthorized reproduction is subject to a \$1000 design fee.

TENANT:

LANDLORD:

AE / PM:

Note: The colors depicted in this design are a graphic representation. Actual colors may vary due to monitors / printers. See color specifications

EXISTING



PROPOSED



NEW PUSH THRU FACES FOR EXISTING D/F BLADE SIGN

QTY: 1 SET (2) TOTAL FOR D/F BLADE SIGN

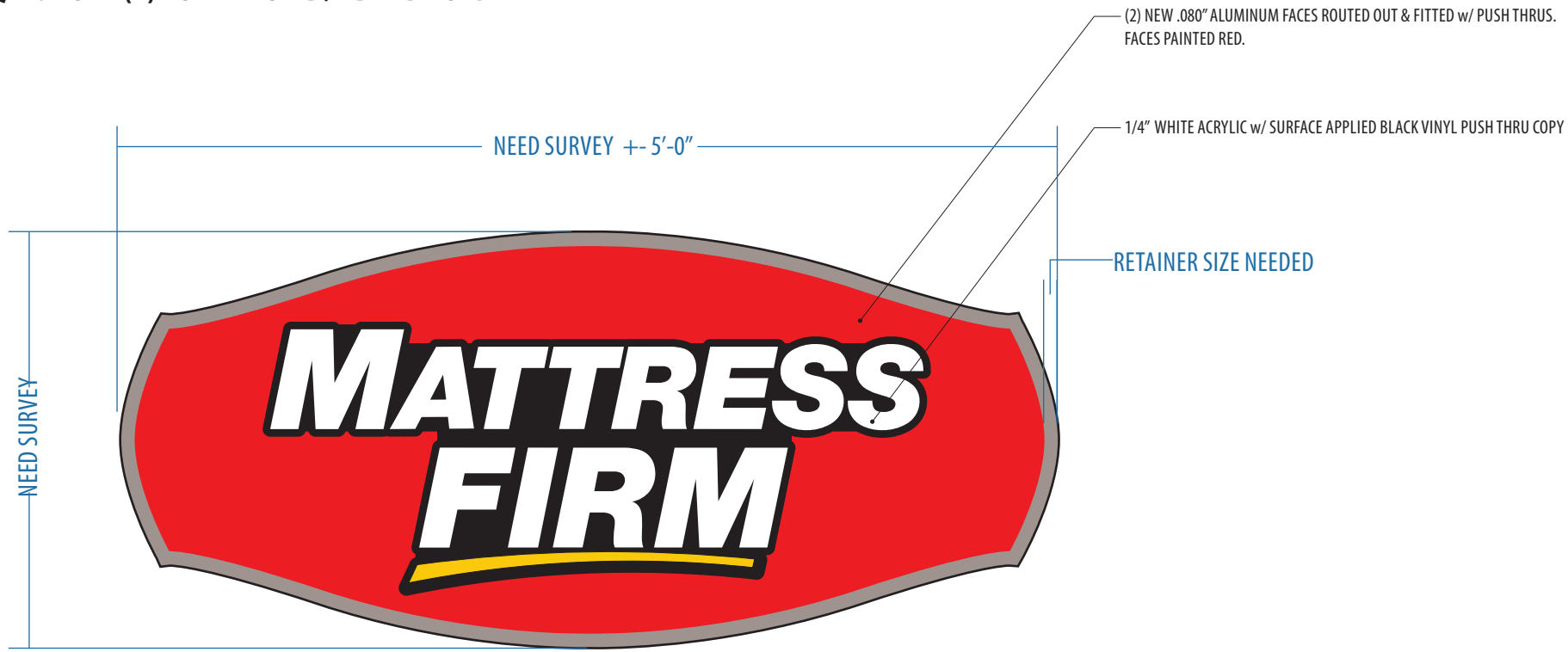

SCALE: NTS

NOTE: SITE SURVEY NEEDED TO DETERMINE EXACT SHAPE / SIZE FOR NEW FACES.

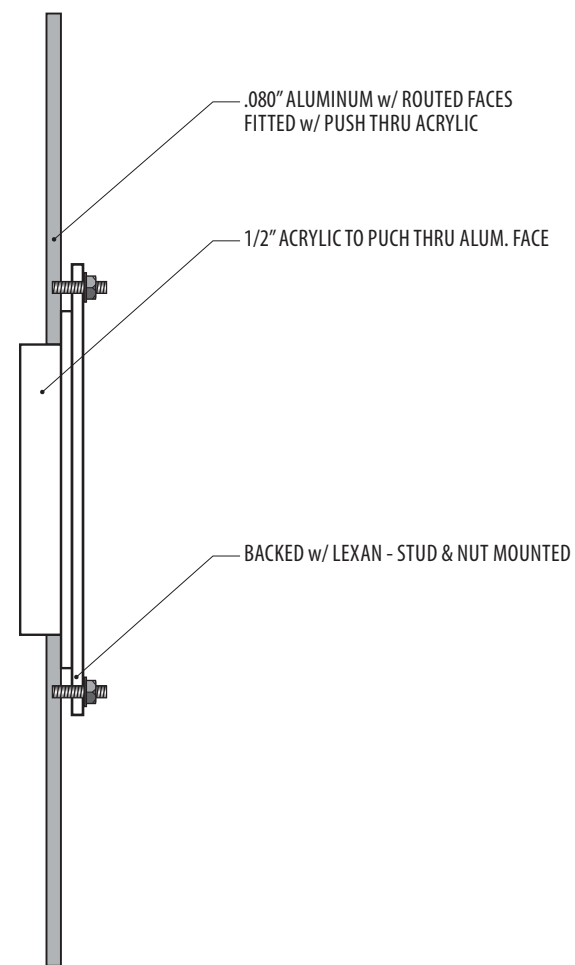

SCALE: NTS



AINOR SIGNS
CL# 913842

5443 Stationers Way, Sacramento, CA 95842
916.348.4370 | fax: 916.348.34375

www.ainorsigns.com

EST#: 00000 JOB#: 13407

PROJECT: Mattress Firm
 ADDRESS: 1415 Van Ness Ave
 CITY, ST: San Francisco CA
 ACCT. REP: Joe Bergh
 DESIGNER: Brian Elie

DATE: 09.19.16
 REVISIONS: A: 10.24.16 B: 10.27.16
 C: 01.30.17 D: 08.02.17 E: 08.09.17
 F: 00.00.00 G: 00.00.00 H: 00.00.00

EXISTING



PROPOSED



APPROVALS

This is an original unpublished drawing created by Aino Signs, Inc. It is submitted for your approval. It is not to be shown to anyone outside your organization, nor is it to be reproduced, copied or exhibited in any fashion. The changing of colors, sizes, materials or illumination method does not alter the design. Ownership of this design is held by Aino Signs, Inc. Authorization to use this design in any fashion must be obtained in writing from Aino Signs, Inc. Any unauthorized reproduction is subject to a \$1000 design fee.

TENANT:

LANDLORD:

AE / PM:

Note: The colors depicted in this design are a graphic representation. Actual colors may vary due to monitors / printers. See color specifications

A 16" Mattress Firm Channel Letters

B 16" Mattress Firm Channel Letters

C New push-thru faces for existing D/F blade sign.

MATTRESS FIRM



AINOR SIGNS
CL# 913842

5443 Stationers Way, Sacramento, CA 95842
916.348.4370 | fax: 916.348.34375

www.ainorsigns.com

EST#: 00000 JOB#: 13407

PROJECT: Mattress Firm

ADDRESS: 1415 Van Ness Ave

CITY, ST: San Francisco CA

ACCT. REP: Joe Bergh

DESIGNER: Brian Elie

DATE: 09.19.16

REVISIONS: A: 10.24.16 B: 10.27.16

C: 01.30.17 D: 08.02.17 E: 08.09.17

F: 00.00.00 G: 00.00.00 H: 00.00.00



SCALE: NTS



APPROVALS

This is an original unpublished drawing created by Ainator Signs, Inc. It is submitted for your approval. It is not to be shown to anyone outside your organization, nor is it to be reproduced, copied or exhibited in any fashion. The changing of colors, sizes, materials or illumination method does not alter the design. Ownership of this design is held by Ainator Signs, Inc. Authorization to use this design in any fashion must be obtained in writing from Ainator Signs, Inc. Any unauthorized reproduction is subject to a \$1000 design fee.

TENANT:

LANDLORD:

AE / PM:

Note: The colors depicted in this design are a graphic representation. Actual colors may vary due to monitors / printers. See color specifications